

DuPont™ Tyvek® HomeWrap® ■ DuPont™ FlexWrap™ ■ DuPont™ StraightFlash™

## How to install Tyvek® HomeWrap® on Vertical Walls, **BEFORE** Windows or Doors are installed

### WRAPPING VERTICAL WALLS:

#### STEP 1

UNWRAP roll at corner, leaving 6"-12" overlap.

Line up printed stud marks with first stud.

#### STEP 2

Roll should be plumb. Bottom roll edges should extend over sill plate interface at least 2" to 3".

For maximum air leakage reduction, SEAL wrap with caulk or tape.

#### STEP 3A

Secure Tyvek® weather resistive barrier every 12"-18" on vertical stud line. With wood, insulated sheathing board or exterior gypsum board, use large head or plastic washer head nails (such as Tyvek® WrapCaps or Wrap Cap Screws), as a best practice. Wide staples with 1.0 inch minimum crown can also be used.

#### STEP 3B

For masonry applications, temporarily attach to masonry, using adhesives with polyurethane, elastomeric or latex base in vertical strips spaced approximately 24" apart. For a list of suggested adhesives, call 1-800-44-TYVEK. Use cladding fasteners as permanent means of attachment.

#### STEP 4

Unroll directly over windows and doors. Upper roll overlaps bottom roll by 6" horizontally.

#### STEP 5

COVER interface of upper and lower top plates with Tyvek®. As a best practice, TAPE all horizontal seams at band joists, headers and roll overlaps with 2" or 3" DuPont™ Tyvek® Tape.

Repair any accidental tears, damage or penetrations with DuPont™ Tyvek® Tape.

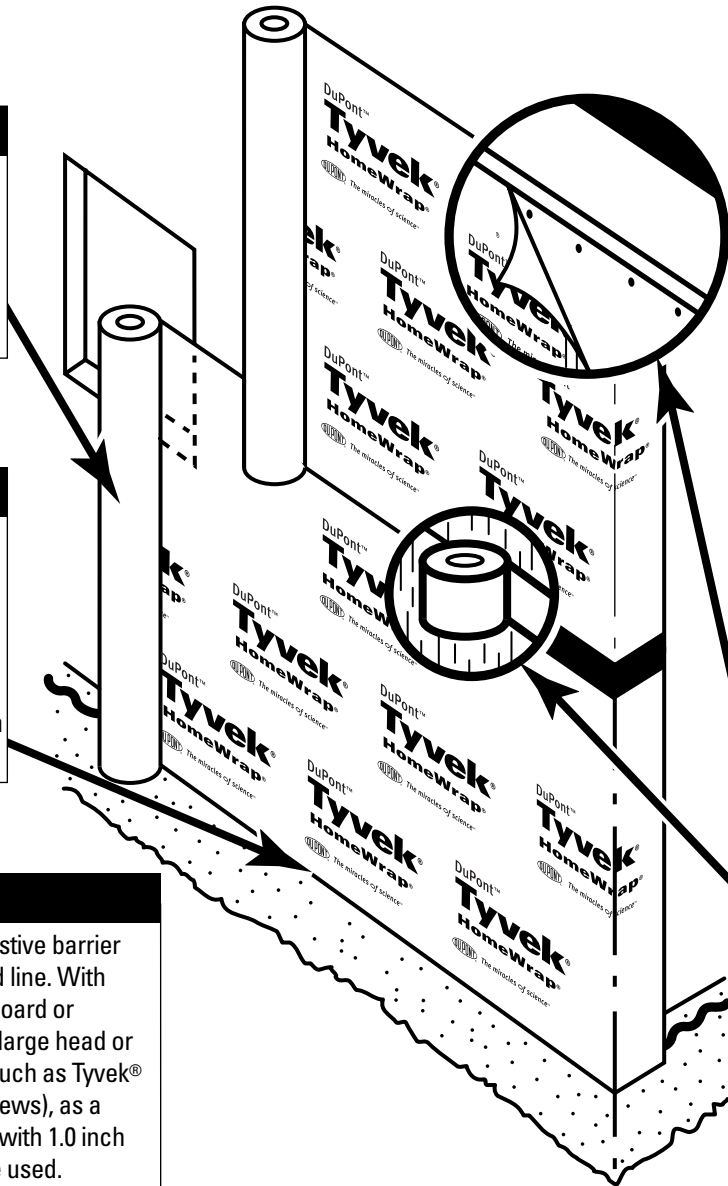

# INSTALLATION GUIDELINES

## for DuPont™ Flashing Systems™ with integral flanged windows

### **AFTER** weather-resistive barrier is installed.

DuPont™ FlexWrap™ and DuPont™ StraightFlash™ are highly engineered flashing tapes designed to be compatible with Tyvek® Weatherization Systems products. For optimal weather-resistive protection, we suggest you use Tyvek® HomeWrap®, Tyvek® StuccoWrap® or Tyvek® CommercialWrap®, DuPont™ Tyvek® Tape, and Tyvek® Wrap Caps.

#### GENERAL INSTRUCTIONS:

- DuPont™ FlexWrap™ and StraightFlash™ should be installed on clean, dry surfaces. Wipe surfaces to remove moisture, dirt, grease and other debris that could interfere with adhesion.
- Apply pressure along entire surface for a good bond.
- Remove all wrinkles and bubbles by smoothing surface and repositioning as necessary.
- DO NOT STRETCH DuPont™ FlexWrap™ WHEN INSTALLING.
- DuPont™ FlexWrap™ performs best when installed at temperatures above 40°F (4°C).
- For additional guidelines and suggested caulks, please call 1-800-44-TYVEK (800-448-9835).

## STEP 6

#### PREPARE WEATHER-RESISTIVE BARRIER FOR WINDOW OR DOOR INSTALLATION:

- Make a modified "I-Cut" in the weather-resistive barrier. Begin with a horizontal cut across the top of the window frame. (For roundtop windows, the cut should begin 2" above the mull joint [see D]). From the center cut straight down about two-thirds of the way then angling the cut to each corner (see A).
- Cut a flap above the rough opening to expose sheathing or framing members and allow head flashing installation. Head flashing should adhere to exposed sheathing or framing members.
- Fold side and bottom flaps into rough opening and secure. Flip head flap up and temporarily secure.

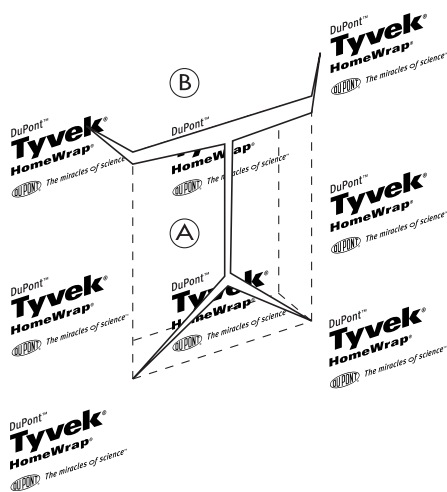

FOR RECTANGULAR WINDOWS

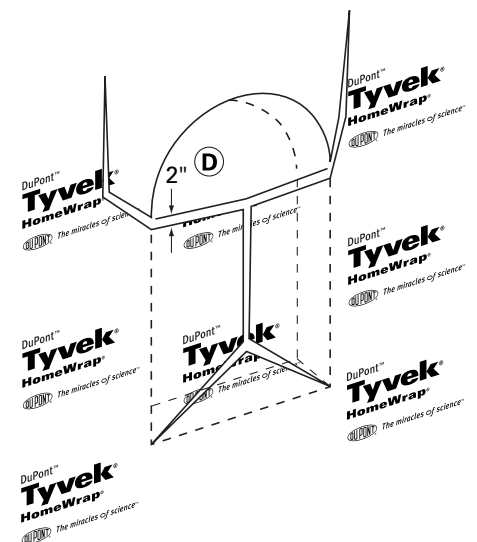
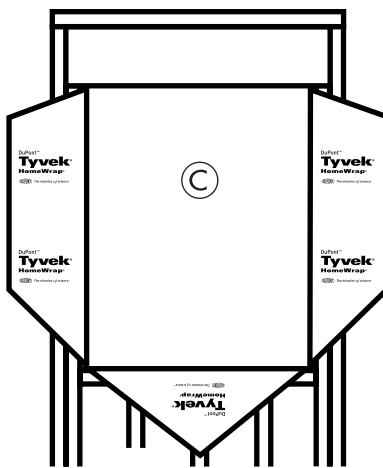

FOR ROUNDTOP WINDOWS

## STEP 7

- Cut DuPont™ FlexWrap™ at least 12" longer than width of rough opening sill (S).
- Remove first piece of release paper, cover horizontal sill by aligning inside edge of sill, and adhere into rough opening across sill and up jambs (min. 6"). Cover horizontal sill by aligning FlexWrap™ edge with inside edge of sill.
- Remove second release paper.

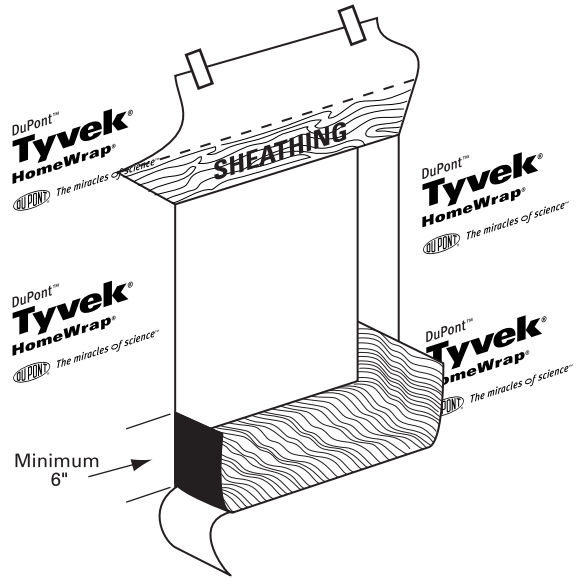
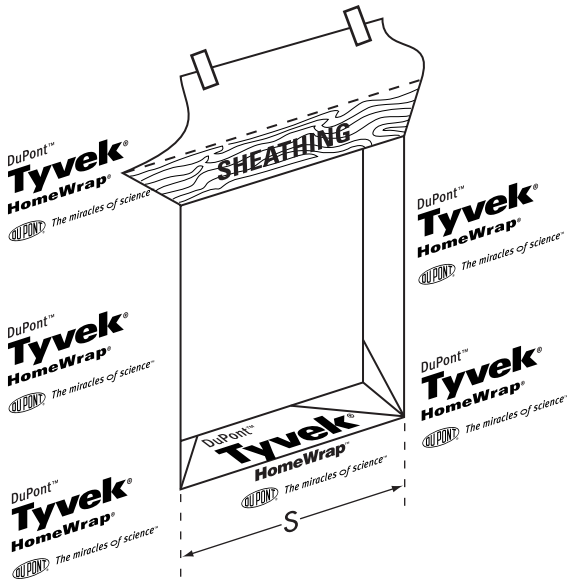

## STEP 8

- Fan DuPont™ FlexWrap™ at bottom corners onto face of wall.
- Firmly press sill flashing to ensure full adhesion.
- SECURE FANNED EDGES WITH MECHANICAL FASTENERS. (i.e. CapNails, staples, screws, etc.)

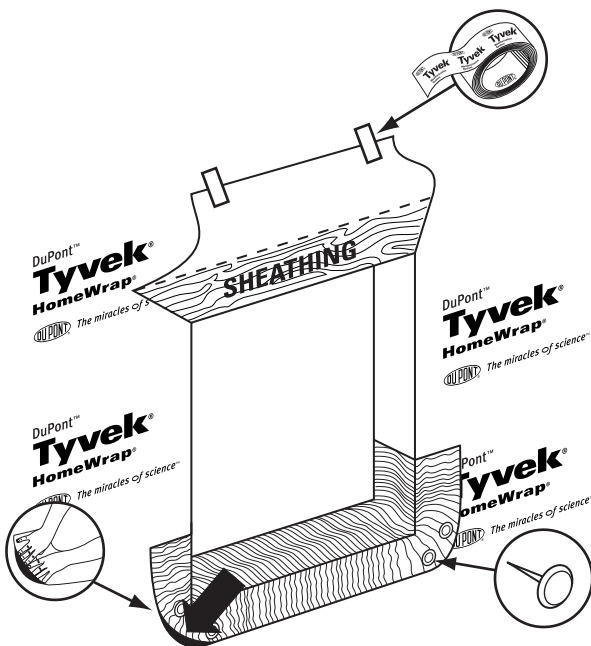

## STEP 9

- Apply continuous bead of caulk to wall or back side of window mounting flange across jambs and head, but leave bottom sill flange uncaulked.
- DO NOT APPLY CAULK ACROSS BOTTOM SILL FLANGE.

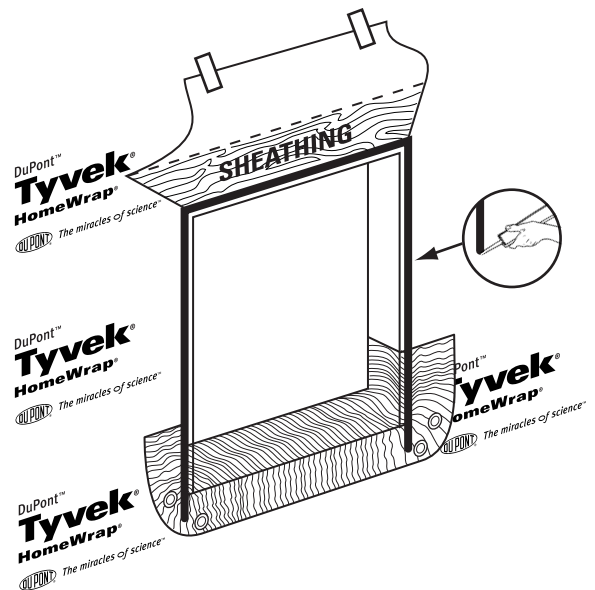

## FOR RECTANGULAR WINDOWS:

### STEP 10

- Install window/door according to manufacturer's instructions. (illustration A)
- Cut two pieces of DuPont™ StraightFlash™ or FlexWrap™ for jamb flashing extending 1" above window head flange and below bottom edge of sill flashing. Remove release paper and press tightly along sides of window frame. (illustration B)
- Cut a piece of DuPont™ StraightFlash™ or FlexWrap™ for head flashing, which extends beyond outer edges of jamb flashings. Remove release paper and install completely covering mounting flange and adhering to exposed sheathing or framing members. (illustration C)

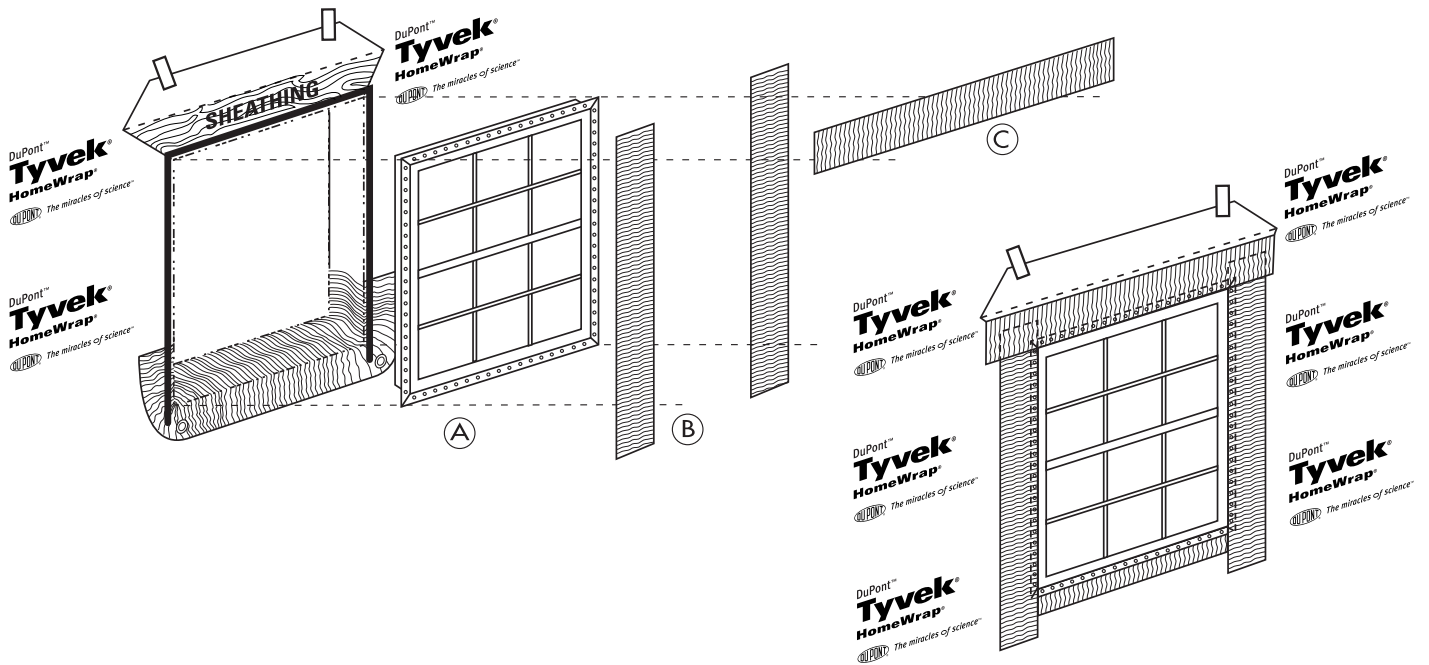

### STEP 11

- Flip down upper flap of weather-resistive barrier so it lays flat across head flashing.
- Tape along all cuts in weather-resistive barrier and across head of the window with DuPont™ Tyvek® Tape.

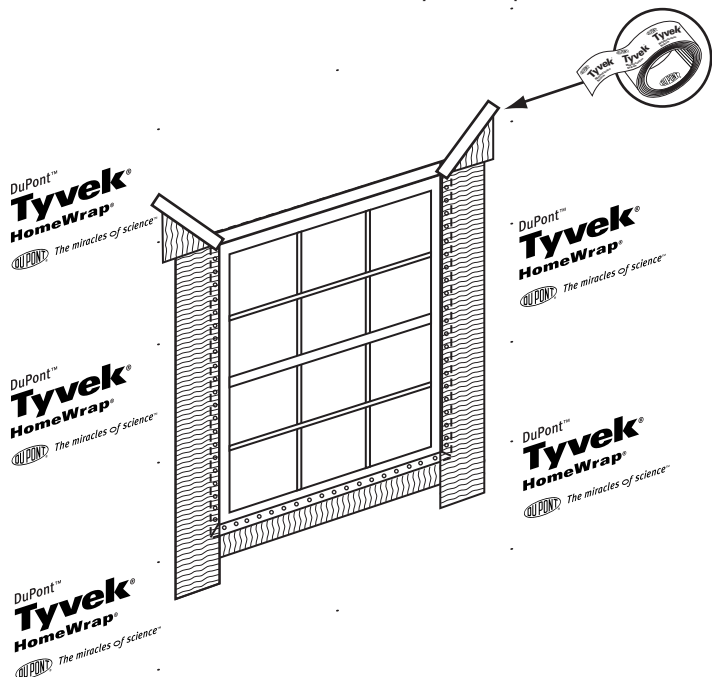

### STEP 12

- Caulk (using backer rod if necessary) to seal rear of window/door frame to inside of rough opening across bottom and a minimum of 12" up the sides to form a back dam. To air seal around the window opening, caulk completely around the back edge of the window perimeter.

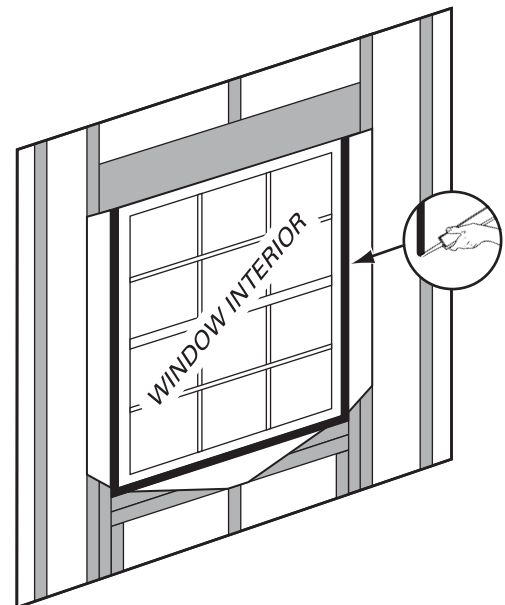

## FOR ROUNDTOP WINDOWS:

### STEP 13

- Cut head flashing at least 12" longer than the arc length (H) of round-top window.
- Remove both release papers and install to conform around top of window, covering entire mounting flange and adhering to exposed sheathing or framing members. Head flashing should overlap jamb flashings at least 6".

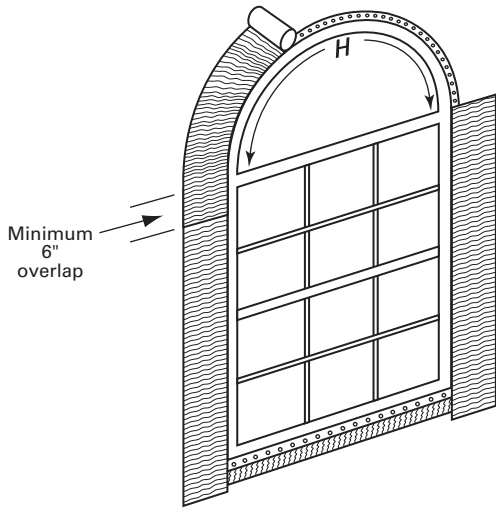

#### INSTALLATION TIP!

Remove short lengths of release papers, begin installation, then repeat until installation is complete.

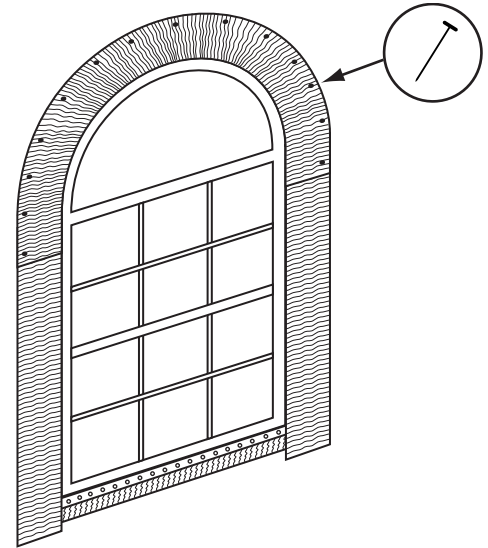

### STEP 15

- Flip down upper flap of weather-resistive barrier so it lays flat across head flashing.
- Tape along all cuts in weather-resistive barrier and across head of the window with DuPont™ Tyvek® Tape.
- Caulk (using backer rod if necessary) to seal rear of window/door frame to inside of rough opening across bottom and a minimum of 12" up the sides to form a back dam. To air seal around the window opening, caulk completely around the back edge of the window perimeter.

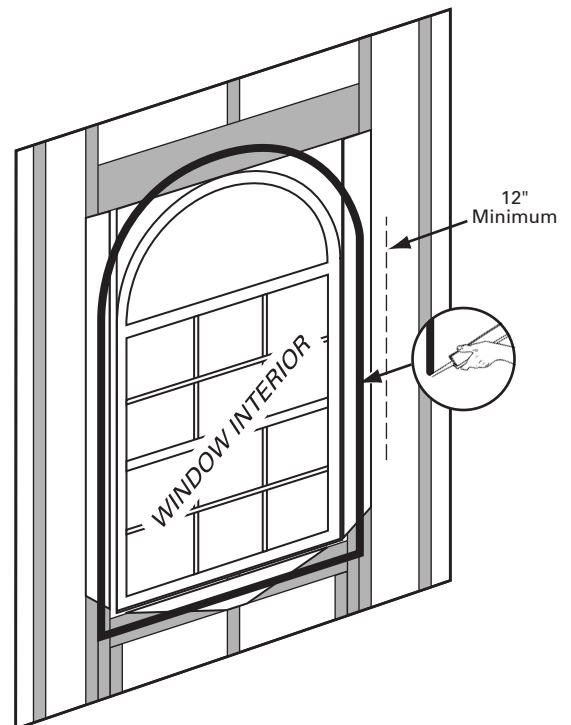
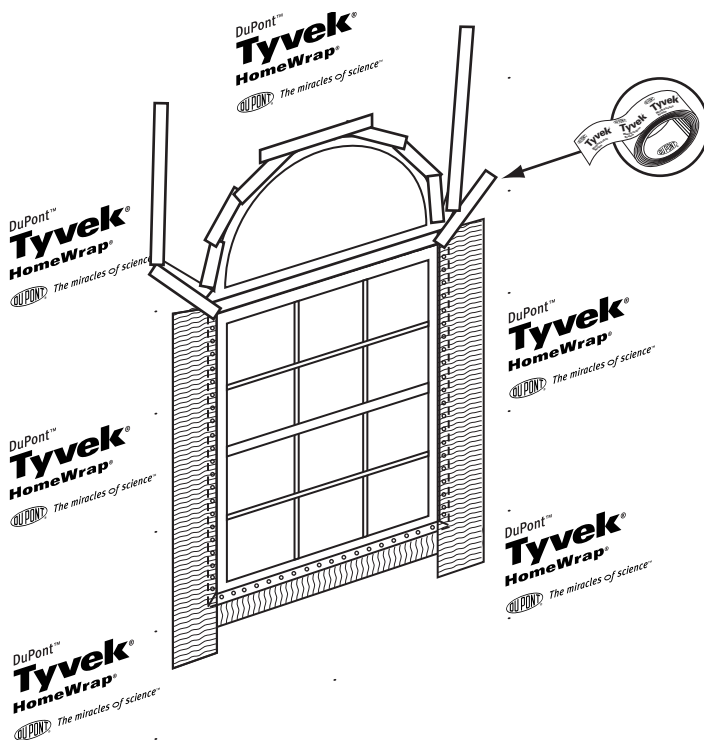

---

## BUILDING CODE REPORTS

National Evaluation Report NER-642. Meets the ASTM E1677 Type 1 Air Retarder when installed according to Tyvek® Weatherization Systems best practices. See installation instructions on label.

---

## TECHNICAL SPECIFICATIONS

Tyvek® used in construction products is made from 100% flash spunbonded high density polyethylene fibers which have been bonded together by heat and pressure, without binders or fillers, into a tough, durable sheet structure. Additives have been incorporated into the polyethylene to provide ultraviolet light resistance. DuPont suggests that Tyvek® be covered within four months (120 days) of installation.

DuPont™ FlexWrap™ and StraightFlash™ are made from a synthetic rubber adhesive and a laminate of polyethylene film, elastic fiber, synthetic rubber adhesive, polyurethane adhesive, and a top sheet of flash spunbonded high density polyethylene fibers. Additives have been incorporated into these materials to provide ultraviolet light resistance. DuPont suggests that DuPont™ FlexWrap™ and StraightFlash™ be covered within four months (120 days) of installation.

---

## PRODUCT GUARANTEE

DuPont will replace any Tyvek® Weatherization System product damaged during installation by weather or normal handling if it is installed according to procedures published by DuPont. If you have any questions, call DuPont™ Tyvek® Weatherization Systems at 1-800-44-TYVEK.

If DuPont™ FlexWrap™ and StraightFlash™ product fails to meet published material specifications at the time of shipment, or contains defects created during its production, DuPont will replace defective material at no charge.

---

## WARNING

Tyvek® is slippery and should not be used in any application where it will be walked on. In addition, because it is slippery, DuPont recommends using kickjacks or scaffolding for exterior work above the first floor. If ladders must be used, extra caution must be taken to use them safely by following the requirements set forth in ANSI Standards 14.1, 14.2 and 14.5 for ladders made of wood, aluminum, and fiberglass, respectively. Tyvek® is combustible and should be protected from a flame and other high heat sources. Tyvek® will melt at 275°F (135°C) and if the temperature of Tyvek® reaches 750°F (400°C), it will burn and the fire may spread and fall away from the point of ignition. For more information, call 1-800-44-TYVEK.

DuPont™ FlexWrap™ and StraightFlash™ and their release paper are slippery and should not be walked on. Remove release paper from work area immediately. DuPont™ FlexWrap™ and StraightFlash™ will melt at temperatures greater than 250°F (121°C). DuPont™ FlexWrap™ and StraightFlash™ are combustible and should be protected from flame and other high heat sources. DuPont™ FlexWrap™ and StraightFlash™ will not support combustion if the heat source is removed. However, if burning occurs, ignited droplets may fall away from the point of ignition. For more information, call 1-800-44-TYVEK.

---

## NOTE

To Achieve greater potential energy savings and weather-resistance, any tears, breaks, holes, etc. created during normal construction should be repaired by taping or patching with Tyvek® weather resistive barriers. When installed in conjunction with other building materials, DuPont™ FlexWrap™ and StraightFlash™ should be properly shingled with these materials, such that water is diverted to the exterior of the wall system. Tyvek® products are weather resistive barriers not the primary water barrier (the outer facade is the primary barrier). Contamination of any Tyvek® weather-resistive barriers and building papers with building site chemicals which increase their wettability (e.g., surfactants) will adversely affect their water-resistance and therefore, their contribution to the overall water-resistance of the wall system. Tyvek® StuccoWrap®, DuPont™ FlexWrap™ and StraightFlash™ are suggested for use as outlined in this brochure. DuPont™ FlexWrap™ and StraightFlash™ are not suggested for use on roof windows. For superior protection against bulk water penetration DuPont suggests a system combining a quality exterior facade, a good secondary weather-resistive membrane and an exterior sheathing, appropriate flashing materials and details; and high quality windows and doors with particular attention to proper installation of each component. In a system where no exterior sheathing is used and Tyvek® is installed directly over the wall studs, exterior facade materials should be selected to ensure maximum protection against water intrusion. Careful workmanship and proper installation of each component is very important.

DuPont believes this information to be reliable and accurate. The information may be subject to revision as additional experience and knowledge is gained. It is the user's responsibility to determine the proper construction materials needed. Because conditions are outside of our control, DUPONT MAKES NO WARRANTIES, EXPRESSED OR IMPLIED, AND ASSUMES NO LIABILITY WHATSOEVER AS TO THE PERFORMANCE OF THE PRODUCTS FOR A PARTICULAR USE. This information is not intended to be used by others for advertising, promotion or other publication for commercial purposes.

For more information:  
**1-800-44-TYVEK**  
**www.Tyvek.com**

DuPont™  
**Tyvek®**  
**HomeWrap®**



*The miracles of science™*