

Every day we work hard to earn your business, blending the talents of our people with the quality of our products and services to exceed your expectations. This is our pledge to you.

Nos esforzamos fuerte diariamente combinando el talento de nuestro personal con la calidad de nuestros productos y servicios excediendo sus expectativas para tenerlo a usted como cliente. Este es nuestro compromiso para con usted.

800-999-5099
www.strongtie.com



INSTALLER'S POCKET GUIDE

GUÍA DE BOLSILLO PARA EL INSTALADOR

S-INSTALL09

The information in this guide is intended to show contractors how our products should be installed. It is not intended for use by Designers. Designers should refer to the current Simpson Strong-Tie® *Wood Construction Connectors* catalog for loads and other critical design information.

La información de esta guía tiene la intención de mostrarles a los contratistas como deben instalar nuestros productos. No está diseñada para que la usen los diseñadores. Los diseñadores deben referirse al catálogo actual de *Conectores para Construcciones de Madera* para determinar las cargas y demás información crítica para el diseño.

QUESTIONS? ¿PREGUNTAS? (800) 999-5099

This guide is intended to provide a quick reference tool to aid in the correct installation of Simpson Strong-Tie® products. It is important that users follow any installation guidelines specified by the Designer and refer to the current Simpson Strong-Tie **Wood Construction Connectors** catalog for other important installation information.

This guide is not intended for use as a design tool by Designers. Please see the current Simpson Strong-Tie **Wood Construction Connectors** catalog for complete technical data and other important design information.

Esta guía tiene como objetivo servir como herramienta de referencia rápida para facilitar la correcta instalación de los productos Simpson Strong-Tie®. Es importante que los usuarios sigan todas las pautas de instalación especificadas por el diseñador y consulten el catálogo de **Conectores para Construcciones de Madera** de Simpson Strong-Tie para obtener más información importante sobre la instalación.

Esta guía no está ideada para ser usada como herramienta de diseño por parte de diseñadores. Consulte el catálogo de **Conectores para Construcciones de Madera** de Simpson Strong-Tie para conocer todos los datos técnicos y otros datos importantes de diseño.

Index/Indexice

SIMPSON
Strong-Tie

A35	17	H1	40-41
AB	18-19	H2.5A	42
ABA	20	H2.5T	43
ABU	21-23	H10	44-45
Adhesive Anchoring/ Anclaje Adhesivo	24-25	HDA	46-47
BC	26	HDQ8	48
BCS2-2/4	27	HDU	49
BC40	28	HETA	50-51
BPS-LBPS	29	HPAHD22	52-53
CB	30-31	HSS	54-55
CBQ	32	HTT	56
CBSQ	33	HTU	57
CC	34	HUS	58-59
CCQ	35	ITS	60-61
CS/CMST14	36-37	ITT	62-63
DTC	38	IUS	64-65
GBC	39	LGT2	66-67

Index/Indexice

SIMPSON
Strong-Tie

LS	68	SP	92
LSSU	69	SP4	93
LSTA	70	SSP	94
LTHJR	71	SSTB	95
LTP4/LTP5	72	STHD	96
LUCZ	73	STC	97
LUS	74-75	SUR/L	98-99
MA	76	THA	100-101
MAB	77-79	THJA	102
MASA/MAS	80-83	THJU	103
MST	84-85	TSB	104-105
PB	86	Titen HD®	106-107
PHD	87	TWB	108-109
PSPN	88	VGT	110-111
RBC	89	VPA	112-113
RSP4	90		
SB	91		

Connectors: Types of Nail Holes

Conectores: Tipos de Agujeros de Clavo

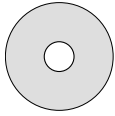

**ROUND
REDONDO**

- **Purpose:**
To fasten a connector.
- **Fill Requirements:**
Always fill, unless otherwise noted.
- **Propósito:**
Para fijar un conector.
- **Requisitos para Llenar:**
Llénelo siempre, salvo que se indique lo contrario.

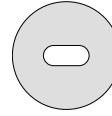

**OBROUND
ALARGADO**

- **Purpose:**
To make fastening a connector in a tight location easier.
- **Fill Requirements:**
Always fill, unless otherwise noted.
- **Propósito:**
Para fijar un conector en una locación apretada con el fin de facilitar el trabajo.
- **Requisitos para Llenar:**
Llénelo siempre, salvo que se indique lo contrario.

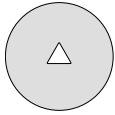

TRIANGULAR

- **Purpose:**
To increase a connector's strength or to achieve MAX strength.
- **Fill Requirements:**
When the Designer specifies "Max" nailing.
- **Propósito:**
Para aumentar la fuerza de un conector o para lograr una fuerza máxima.
- **Requisitos para Llenar:**
Llénelo cuando el diseñador lo especifica clavado "Máx."

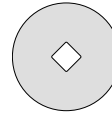

**DIAMOND
DIAMANTE**

- **Purpose:**
To temporarily fasten a connector to make installing it easier.
- **Fill Requirements:**
None.
- **Propósito:**
Para fijar temporalmente un conector, con el propósito de facilitar su instalación.
- **Requisitos para Llenar:**
Ninguno.

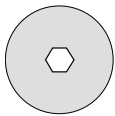

HEXAGONAL

- **Purpose:**
To fasten a connector to concrete or masonry.
- **Fill Requirements:**
Always fill when fastening a connector to concrete or fastening a connector with masonry screws.

- **Propósito:**
Para fijar un conector a concreto o mampostería.
- **Requisitos para Llenar:**
Siempre llénelo al fijar un conector a concreto o al fijar un conector con tornillos de mampostería.

Connectors: Types of Nail Holes

Conectores: Tipos de Agujeros de Clavo

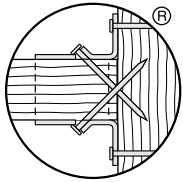

DOUBLE-SHEAR NAILING

CLAVADO DE DOBLE PENETRACIÓN

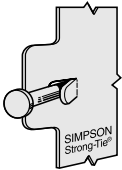
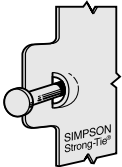

- **Purpose:**
Installed into the joist and header, distributing the load through two points on each joist nail for greater strength. Must use full length nail.
- **Fill Requirements:**
Always fill, and make sure you use the right nail.
- **Propósito:**
Para lograr mayor fuerza, los clavos penetran a la vigueta y la viga cabezal, así distribuyendo la carga entre las dos puntas de cada clavo.
- **Requisitos para Llenar:**
Llénelo siempre, y asegúrese de usar el clavo correcto.

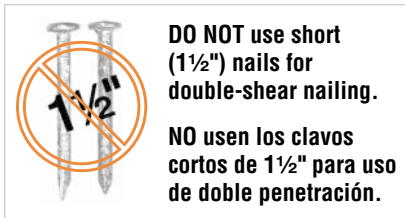

DO NOT use short (1½") nails for double-shear nailing.

NO usen los clavos cortos de 1½" para uso de doble penetración.

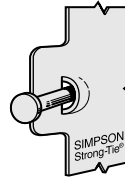

DOME NAILING U.S. Patent No. 5,603,580

CLAVADO CON CÚPULA Patente de EE. UU. No. 5,603,580

- **Purpose:**
To guide the nail into the joist and header at a 45° angle.
- **Fill Requirements:**
Always fill, and make sure you use the right nail.
- **Propósito:**
Con este dispositivo se guían el clavo en la vigueta y la viga cabezal en ángulo de 45°.
- **Requisitos para Llenar:**
Llénelo siempre, y asegúrese de usar el clavo correcto.

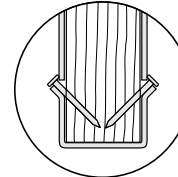

POSITIVE-ANGLE NAILING

CLAVADO EFECTIVO EN ÁNGULO

- **Purpose:**
Provided when wood splitting may occur, and to speed installation.
- **Fill Requirements:**
Always fill, and make sure you use the right nail.
- **Propósito:**
Se usa cuando la madera puede rajarse o abrirse y con el propósito hacer más rápida la instalación.
- **Requisitos para Llenar:**
Llénelo siempre, y asegúrese de usar el clavo correcto.

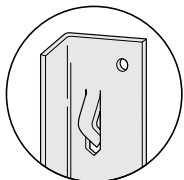

SPEED PRONGS

- **Purpose:**
To temporarily position and secure the connector for easier and faster installation.
- **Fill Requirements:**
None.

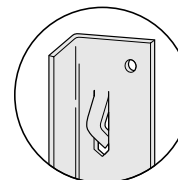

DIENTES RÁPIDOS

- **Propósito:**
Se usan para colocar el conector y fijarlo temporalmente, con el fin de facilitar y hacer más rápida su instalación.
- **Requisitos para Llenar:**
Ninguno.

Fasteners/Clavos

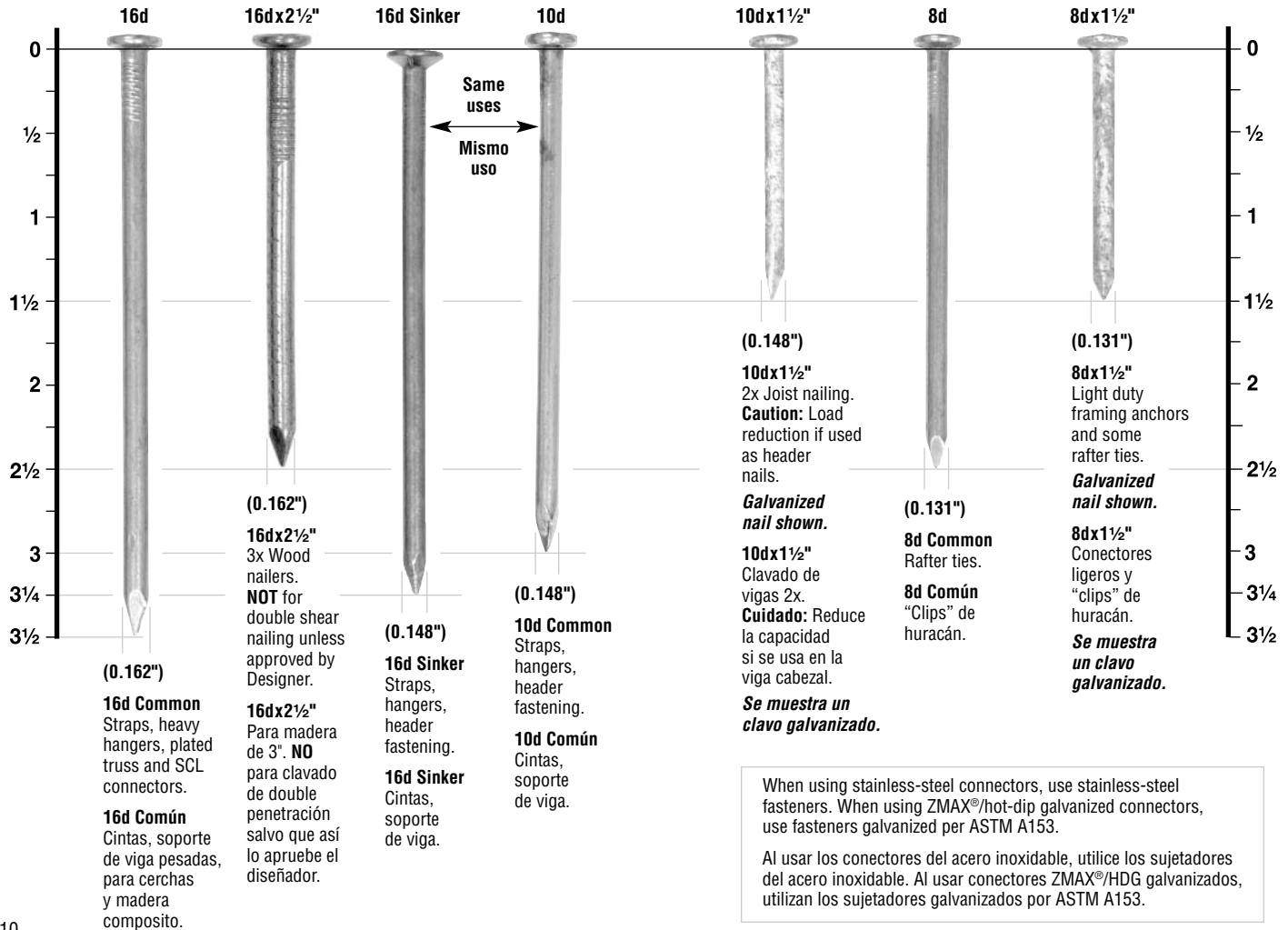

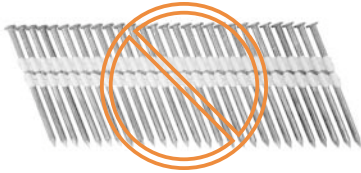

Framing nail-gun nails can only be used if:

1. Correct diameter and length
2. Correct quantity is installed
3. Driven with a hole location tool (*finds the hole*) or by hand

NOTE: .121 may NOT be used to replace 10d or 16d nails.

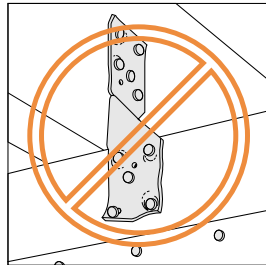

Sólo se pueden utilizar clavos estructurales para pistola si:

1. Tengan diámetro y tamaño correcto
2. Se instala la cantidad correcta
3. Usan maquina que encuentre el agujero, o se clavan a mano

NOTA: NO se pueden utilizar clavos 121 como sustitutos de clavos 10d o 16d.

**DO NOT OVERDRIVE
NO SHOOTING-THRU
CONNECTORS**

**NO SE METE
DEMASIADO**

**NO SE PUEDE
HACER AGUJEROS
CON MAQUINA**



Common screws may NOT be used to replace NAILS in connectors.

NO se puede usar tornillos comunes en vez de CLAVOS en conectores.

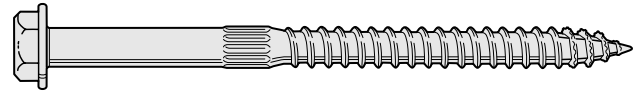

Some connectors install with the Simpson Strong-Tie® Strong-Drive® (SDS) 1/4" structural wood screw.

1. Install with 3/8" hex socket or nut driver
2. Pre-drilling generally not required
3. Do not substitute with lag screws

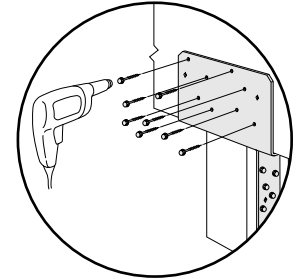

Algunos conectores se instalan con el tornillo para madera estructural Strong Drive® (SDS) de 1/4" de Simpson Strong-Tie®.

1. Instalar con un destornillador de casquillo hexagonal o de tuercas de 3/8"
2. Generalmente no es necesario efectuar perforaciones previas
3. No sustituir con tirafondos



MACHINE BOLT
Diameter: 1/2, 5/8, 3/4, 7/8, 1

PERNOS
Diametro: 1/2, 5/8, 3/4, 7/8, 1

General Connector Installation Instalación de Conectores en General

TOP FLANGE HANGERS / SOPORTES CON ALA SUPERIOR

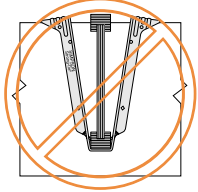

Hanger over-spread
Soporte demasiado abierto

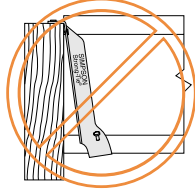

Hanger not plumb
Soporte fuera de plomo

WOOD NAILERS / LISTONES CLAVADORES DE MADERA

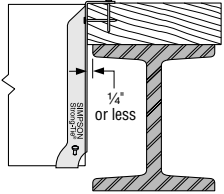

Correct attachment
Montaje correcto

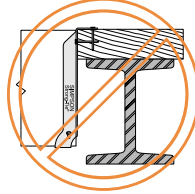

Nailer too wide
Listón clavador muy ancho

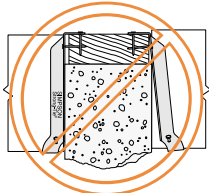

Nailer too narrow
Listón clavador muy estrecho

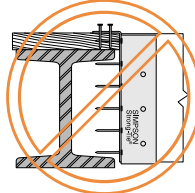

Nailer too thin
Listón clavador demasiado delgado

PREVENT ROTATION / EVITAR LA ROTACIÓN

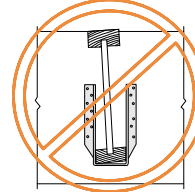

Shorter hanger with no web stiffener
results in rotation
Un soporte colgante más corto sin de
entramado permitirá la rotación

TOE-NAILING / CLAVADO EN DIAGONAL

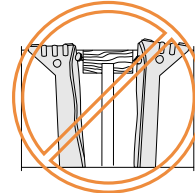

Do not toe nail I-joists before installing
top flange or face mount hangers
No clave en ángulo las viguetas 'I' antes
de montar los soportes (*con o sin ala
superior*)

POSITIVE ANGLE NAILING CLAVADO EFECTIVO EN ÁNGULO

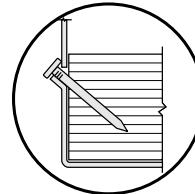

Correct nailing
approx. 45° angle
Clavado correcto
aproximadamente
a 45°



Nail at wrong angle
Clavado con un
ángulo incorrecto

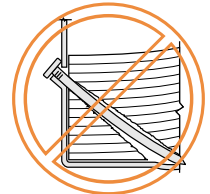

Nail too long
Clavos demasiado
largos

General Connector Installation

Instalación de Conectores en General

ITS/IUS HANGERS / SOPORTES DE ITS/IUS

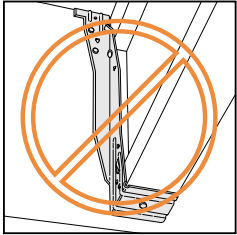

DO NOT make your own holes
DO NOT nail bottom chord
NO haga otros orificios para los clavos
NO clave en la viga inferior

DOUBLE SHEAR NAILING

CLAVADO DE DOBLE PENETRACIÓN

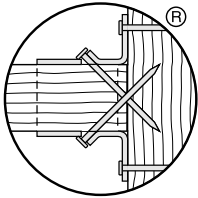

Double-shear nailing must use full length 10d or 16d common nails
 Al trabajar con clavado de doble penetración, se deben emplear clavos comunes 10d o 16d de longitud normal



Shorter nails may not be used as double-shear nails
 No se pueden utilizar clavos más cortos como clavos de doble penetración

A35

SIMPSON
Strong-Tie

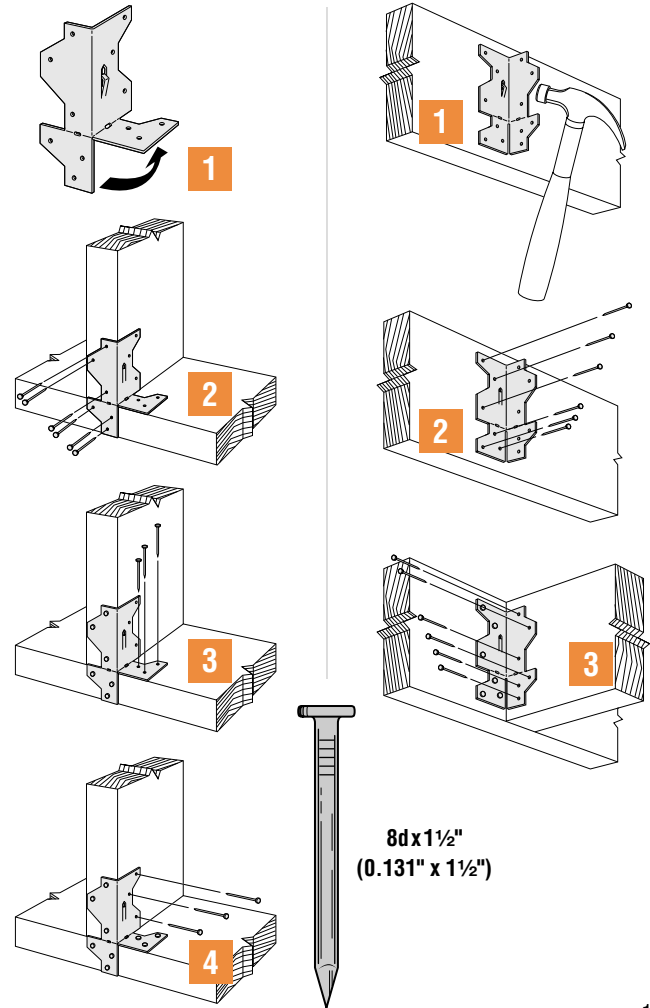

8d x 1/2"
 (0.131" x 1/2")

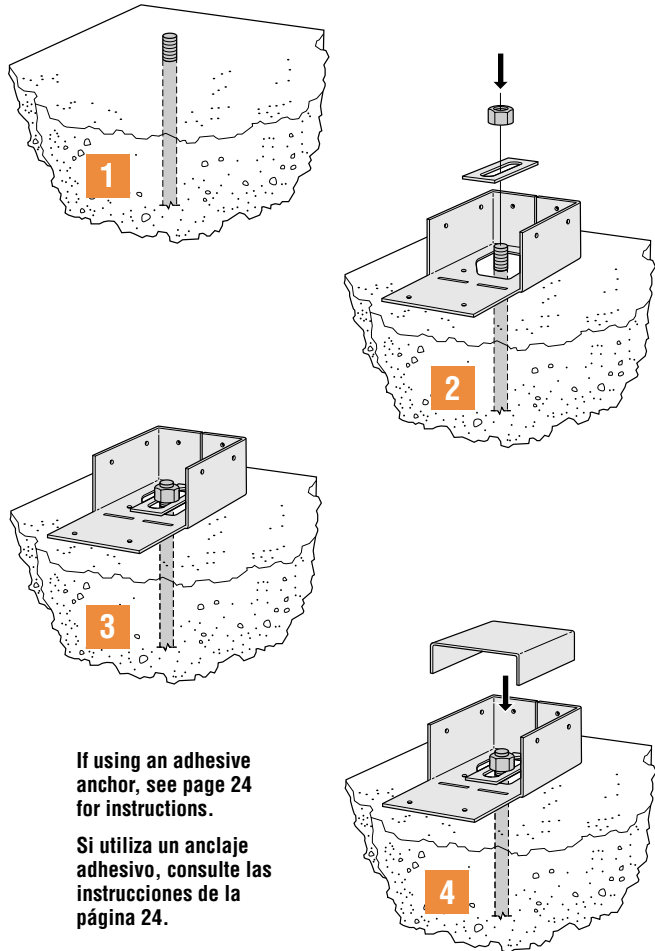

If using an adhesive anchor, see page 24 for instructions.

Si utiliza un anclaje adhesivo, consulte las instrucciones de la página 24.

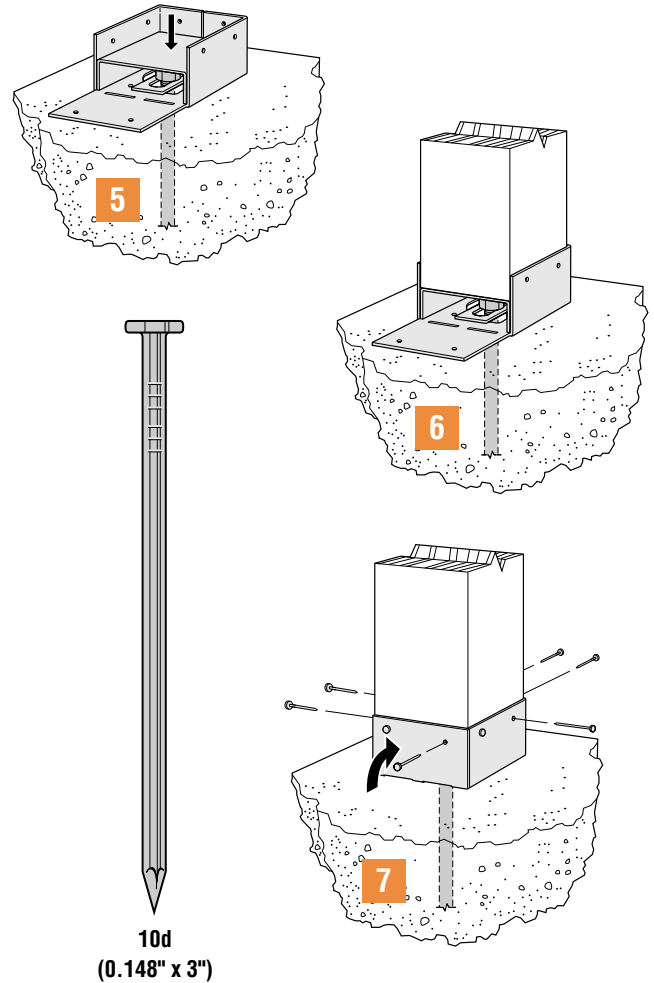

ABA

SIMPSON
Strong-Tie

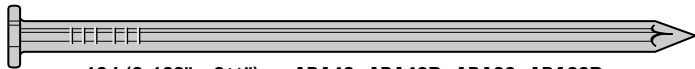
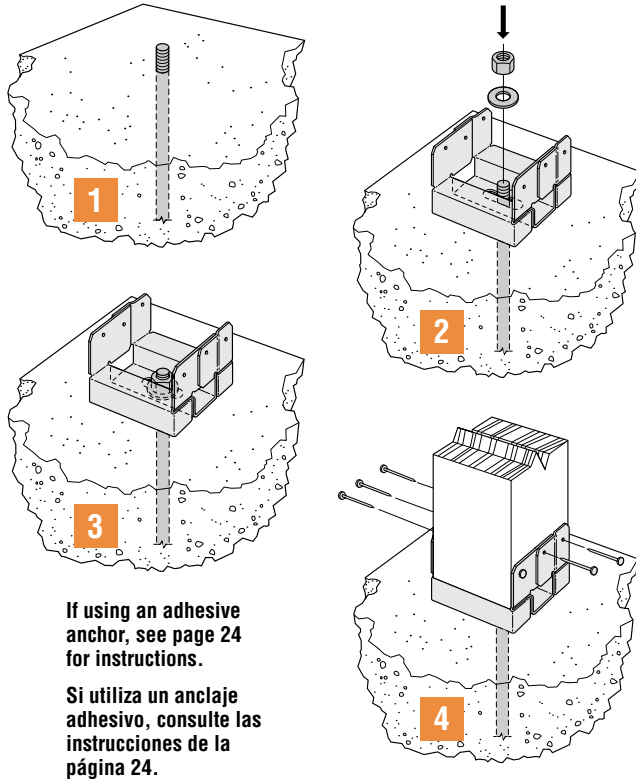

16d (0.162" x 3½") – ABA46, ABA46R, ABA66, ABA66R

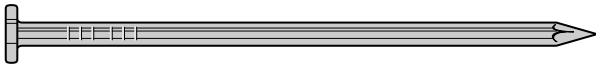

10d (0.148" x 3") – ABA44, ABA44R

ABU – Nails/Clavos

SIMPSON
Strong-Tie

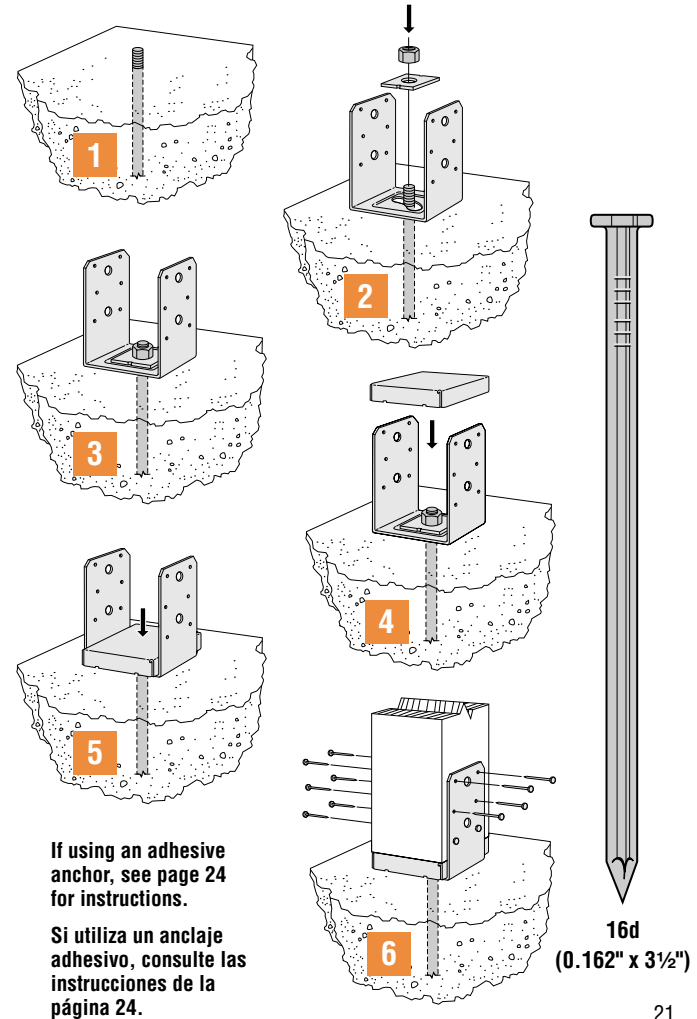

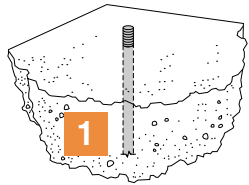

1

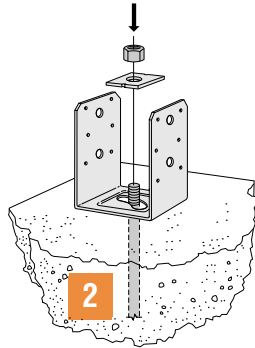

2

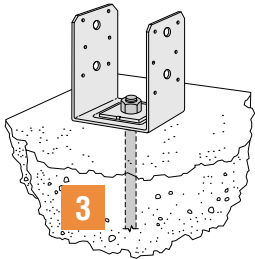

3

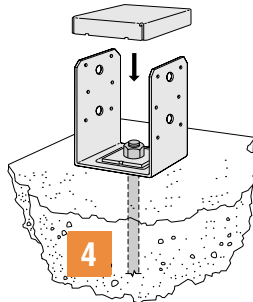

4

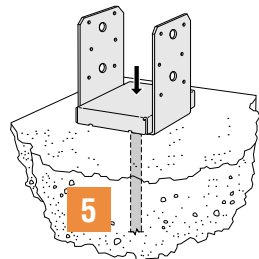

5

If using an adhesive anchor, see page 24 for instructions.

Si utiliza un anclaje adhesivo, consulte las instrucciones de la página 24.

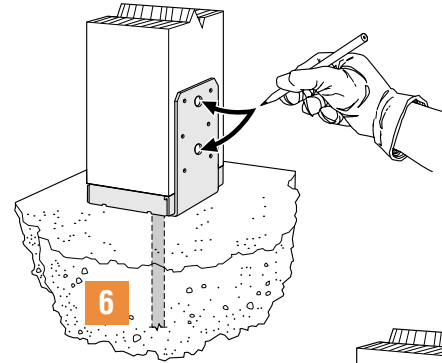

6

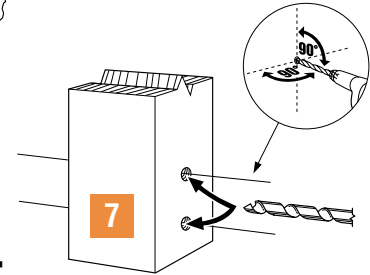

7

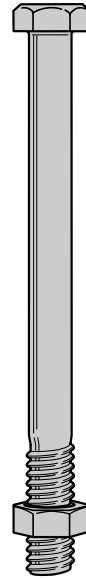

Machine Bolt
Diameter: 1/2"
Length:
ABU44/ABU46 = 4 1/2"
ABU66 = 6 1/2"

Bolt holes must be a minimum of 1/32" and a maximum of 1/16" larger than bolt diameter.

Perno Torneado
Diámetro: 1/2"
Largo:
ABU44/ABU46 = 4 1/2"
ABU66 = 6 1/2"

Los orificios para los pernos deben ser al menos 1/32" y como máximo 1/16" más grandes que el diámetro del perno.

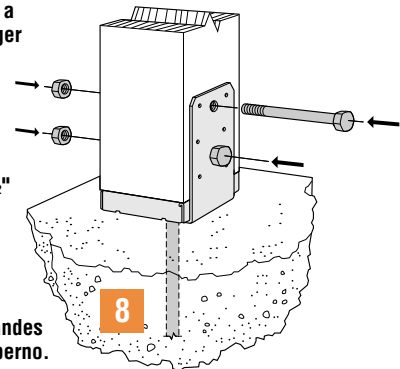

8

Adhesive Anchoring Anclaje Adhesivo

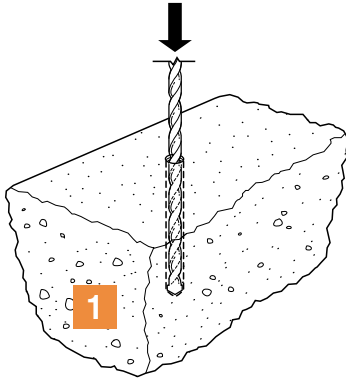

1

Compressed air
(80 psi min.),
4 seconds (min.)
Aire comprimido
(80 psi mín.),
4 segundos (mín.)

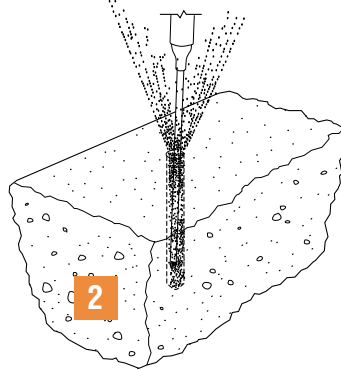

2

Nylon brush
4 cycles (min.)
Cepillo de nylon
4 ciclos (min.)

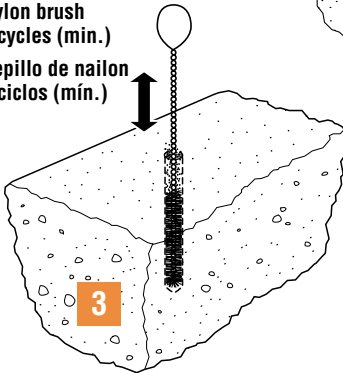

3

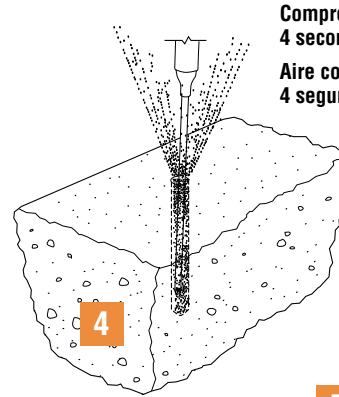

4

Compressed air (80 psi min.),
4 seconds (min.)
Aire comprimido (80 psi mín.),
4 segundos (mín.)

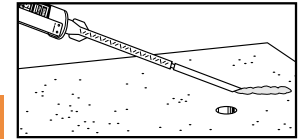

5

Dispense until uniform color
Aplique hasta lograr un color
uniforme

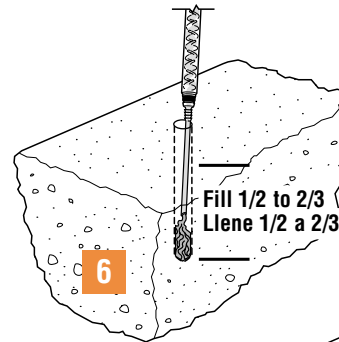

6

Fill 1/2 to 2/3
Llene 1/2 a 2/3

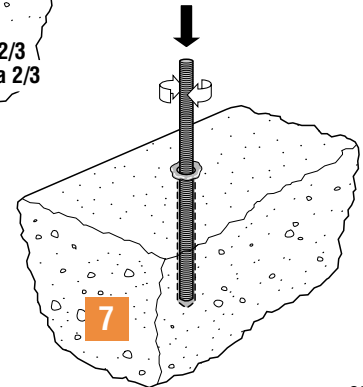

7

BC

SIMPSON
Strong-Tie

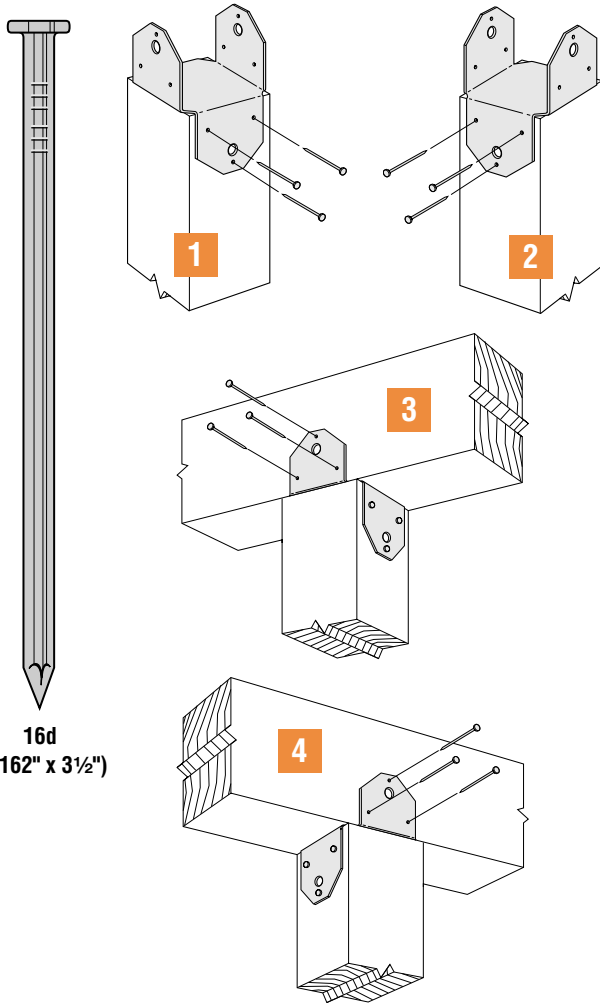

BCS2-2/4

SIMPSON
Strong-Tie

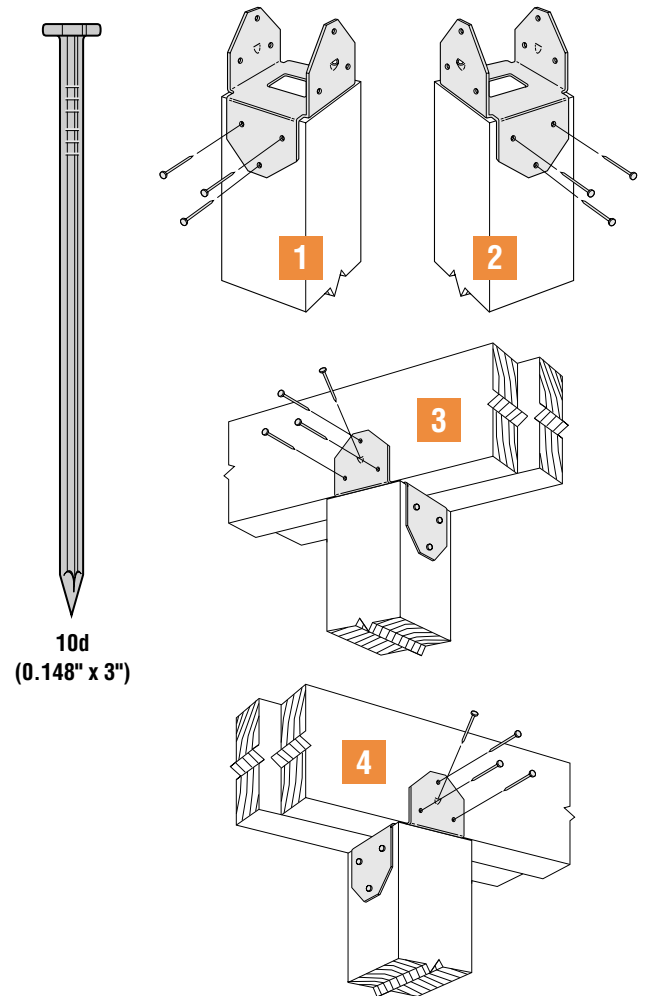

BC40

SIMPSON
Strong-Tie

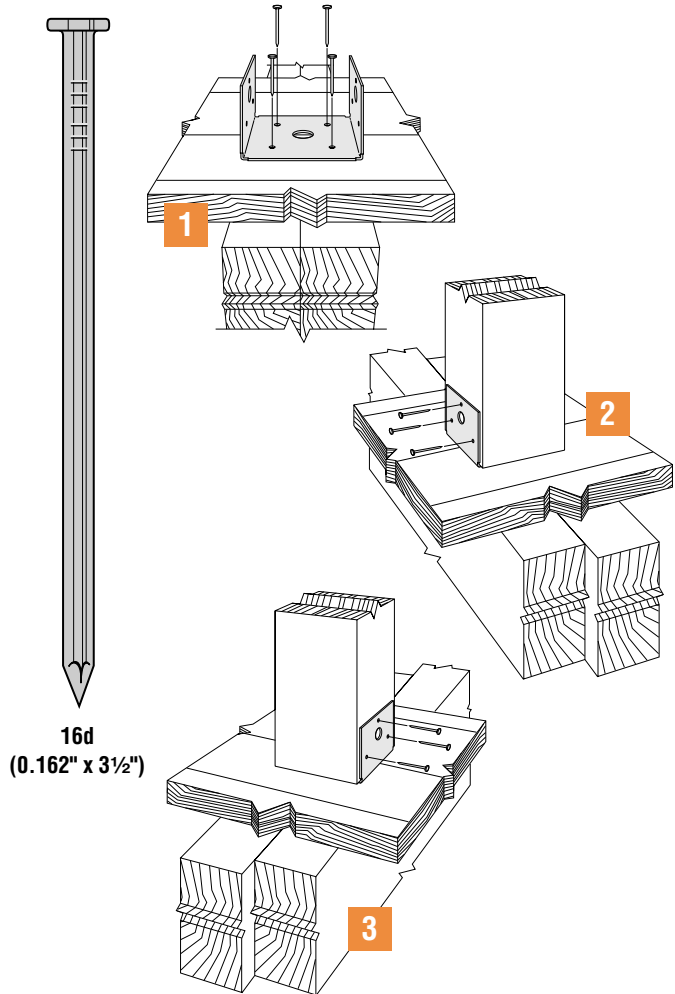

BPS-LBPS

SIMPSON
Strong-Tie

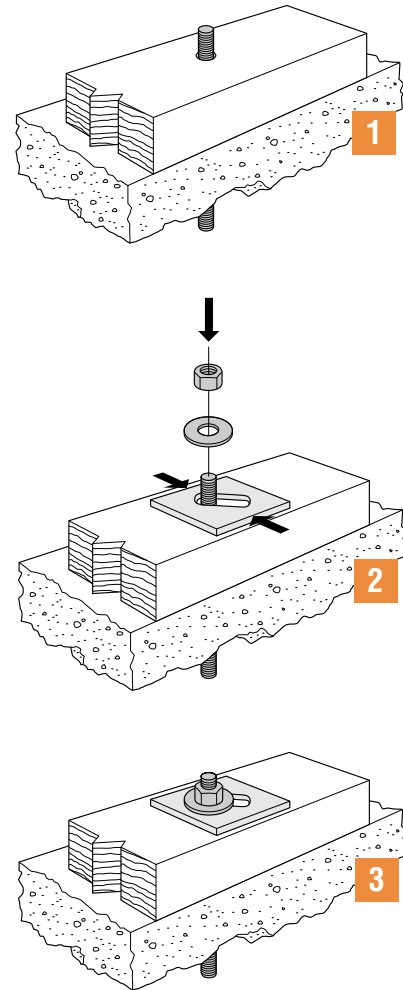

CB – Machine Bolts/Pernos

SIMPSON
Strong-Tie

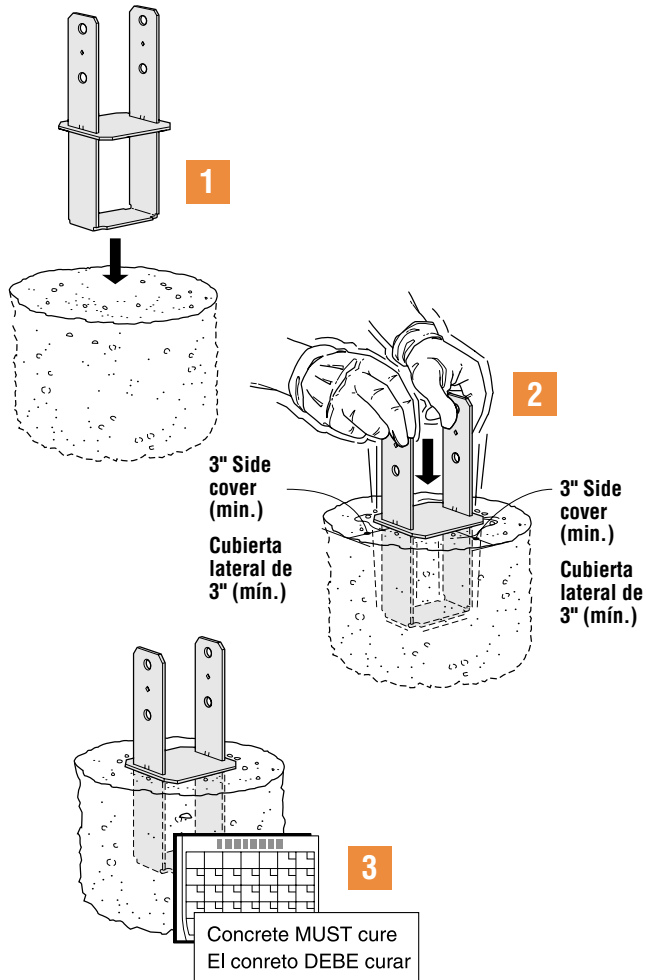

CB – Machine Bolts/Pernos

SIMPSON
Strong-Tie

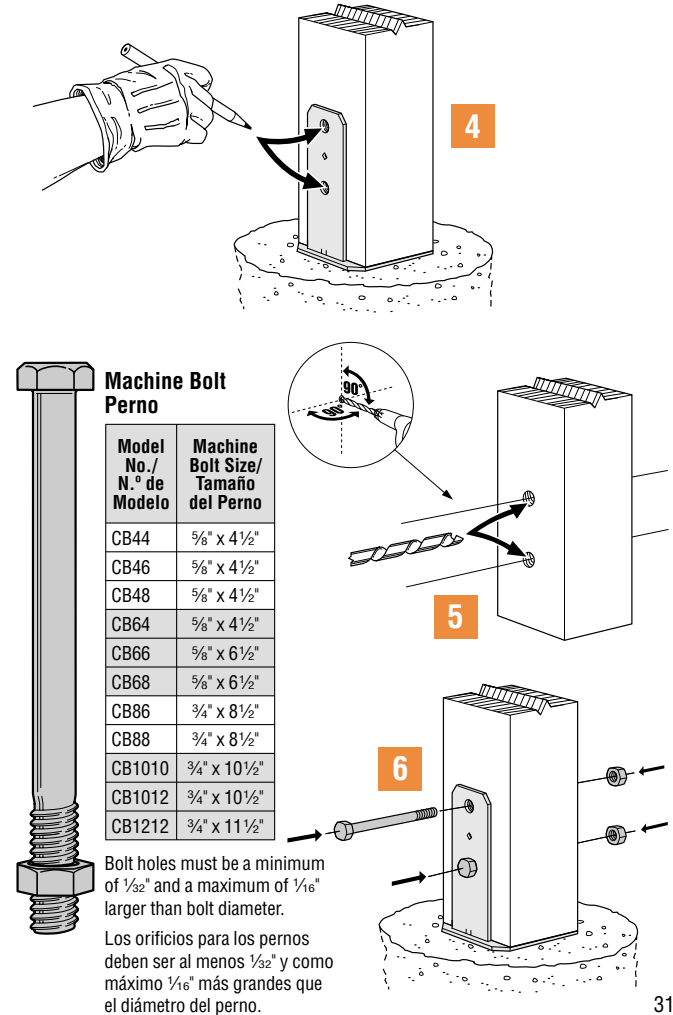

CBQ

SIMPSON
Strong-Tie

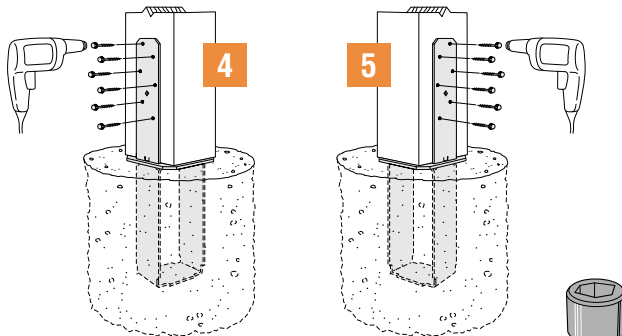
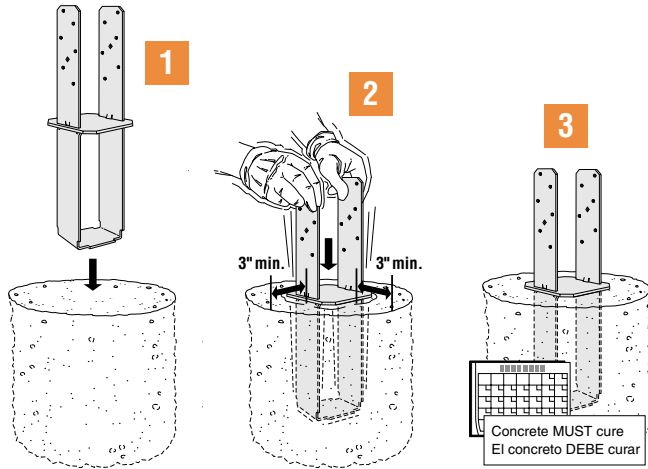

SDS 1/4" x 2"

Use 3/8"
driver
Use un
destornillador
de 3/8"

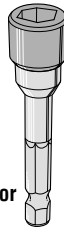

CBSQ

SIMPSON
Strong-Tie

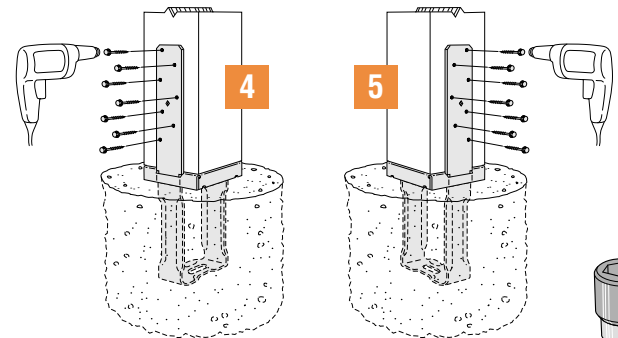
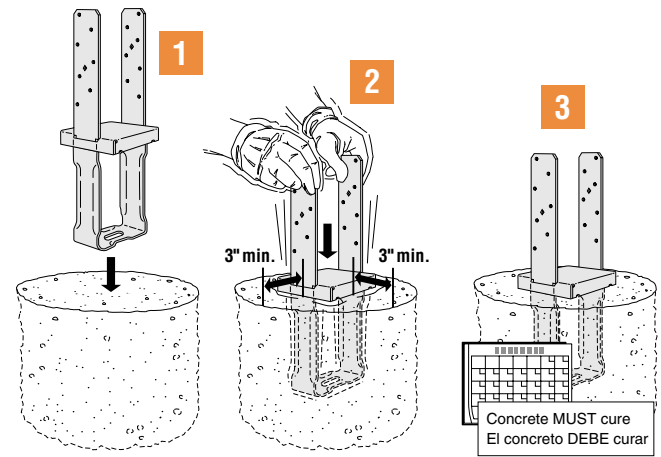

SDS 1/4" x 2"

Use 3/8"
driver
Use un
destornillador
de 3/8"

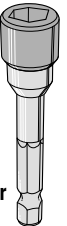

CC – Machine Bolts/Pernos

SIMPSON
Strong-Tie

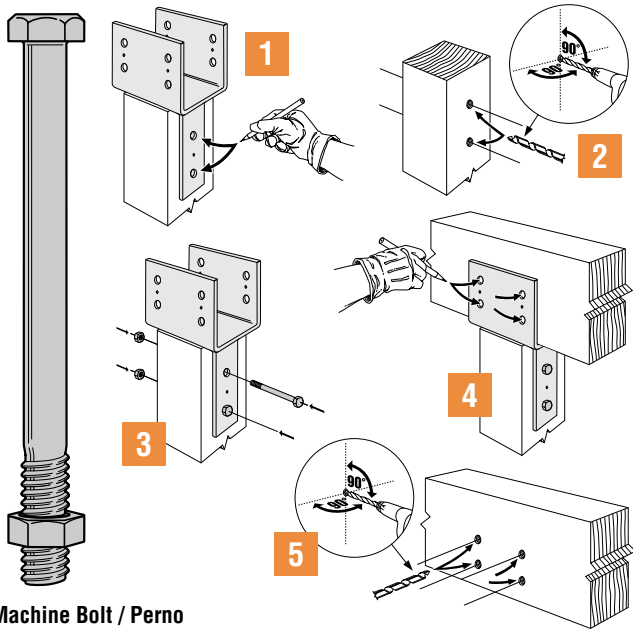

Machine Bolt / Perno

Beam or Column Width Ancho de Dintel o de Columna	Machine Bolt Size Tamaño del Perno Torneado	
	Diameter Diámetro	Length Longitud
3 1/8"	5/8"	4 1/2"
3 1/2"	5/8"	4 1/2"
5 1/8"	3/4"	6 1/2"
5 1/2"	5/8"	6 1/2"
6 3/4"	3/4"	8"
7"	3/4"	8"
7 1/2"	3/4"	8 1/2"
8 3/4"	3/4"	10"
9 1/2"	3/4"	10 1/2"

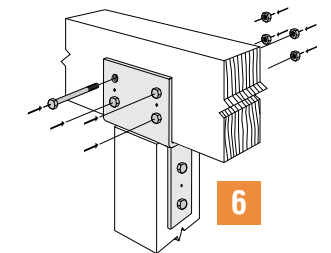

Bolt holes must be a minimum of 1/32" and a maximum of 1/16" larger than bolt diameter.

Los orificios para los pernos deben ser al menos 1/32" y como máximo 1/16" más grandes que el diámetro del perno.

CCQ

SIMPSON
Strong-Tie

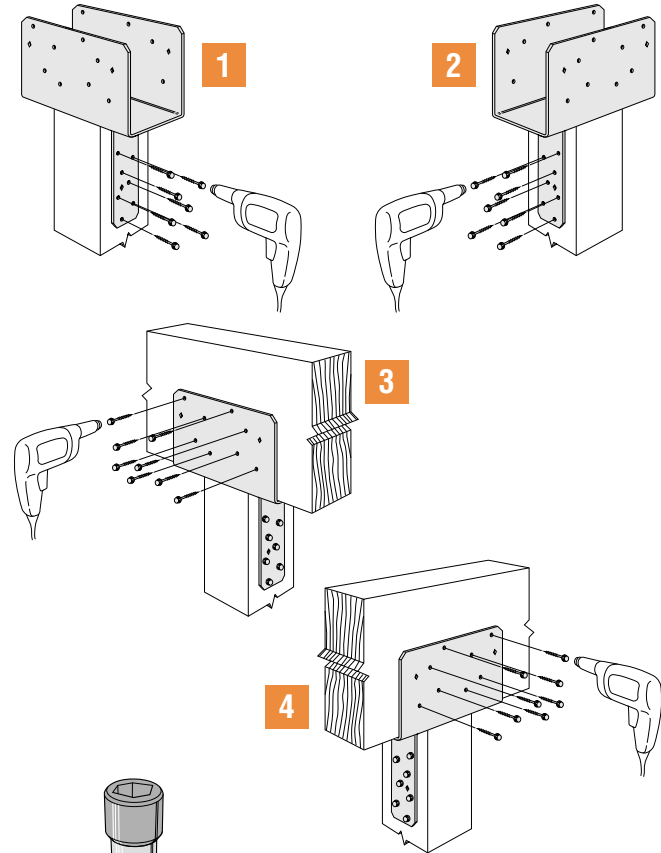

Use 3/8" driver

Use un destornillador de 3/8"

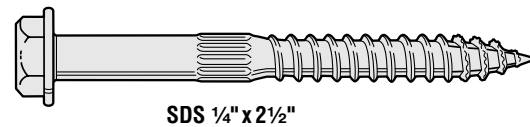
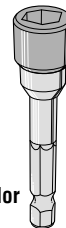

SDS 1/4" x 2 1/2"

CS/CMST14

SIMPSON
Strong-Tie

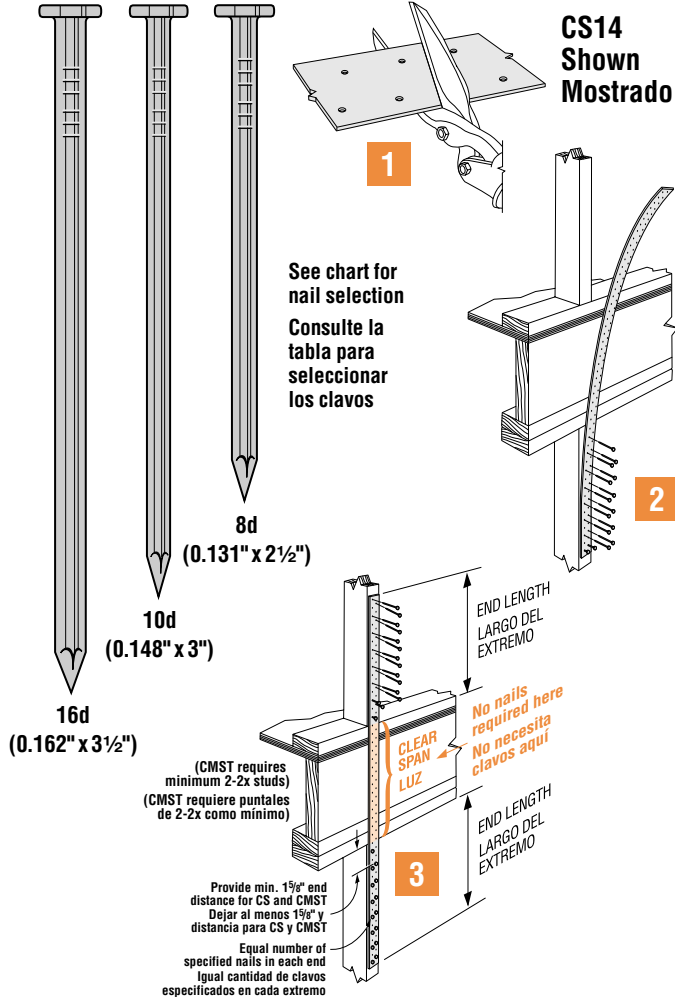

CS/CMST14

SIMPSON
Strong-Tie

Across Joists Sobre Varias Viguetas

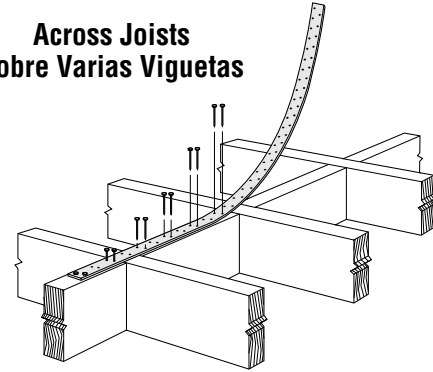

Model/ Modelo	Lumber Species / Especies de Madera					
	Douglas Fir-Larch/Southern Pine			Spruce-Pine-Fir/HemFir		
	End Length/ Largo del Extremo	Cut Length/ Largo a Cortar	Total Fasteners/ Total de Clavos	End Length/ Largo del Extremo	Cut Length/ Largo a Cortar	Total Fasteners/ Total de Clavos
CS14	15"	Clear Span (Luz)+30"	26-10d	16"	Clear Span (Luz)+32"	30-10d
CS14-R	16"	Clear Span (Luz)+32"	30-8d	19"	Clear Span (Luz)+38"	36-8d
CS16	13"	Clear Span (Luz)+26"	22-8d	14"	Clear Span (Luz)+28"	26-8d
CS16-R	11"	Clear Span (Luz)+22"	20-10d	12"	Clear Span (Luz)+24"	22-10d
CS18S	11"	Clear Span (Luz)+22"	18-8d	12"	Clear Span (Luz)+30"	22-8d
CS18S	9"	Clear Span (Luz)+18"	16-10d	10"	Clear Span (Luz)+24"	18-10d
CS18-R						
CS20	9"	Clear Span (Luz)+18"	14-8d	9"	Clear Span (Luz)+18"	16-8d
CS20-R	6"	Clear Span (Luz)+16"	12-10d	8"	Clear Span (Luz)+16"	14-10d
CS22	6"	Clear Span (Luz)+16"	14-8d	8"	Clear Span (Luz)+20"	14-8d
CS22-R	5"	Clear Span (Luz)+14"	12-10d	7"	Clear Span (Luz)+18"	12-10d
CMST14	26"	Clear Span (Luz)+52"	56-16d	30"	Clear Span (Luz)+66"	66-16d
	30"	Clear Span (Luz)+60"	66-10d	34"	Clear Span (Luz)+76"	76-10d

NOTE: Install half of the total fasteners in each end of strap.

Clear Span = Luz

NOTA: Instale la mitad de la cantidad total de sujetadores en cada extremo del fleje.

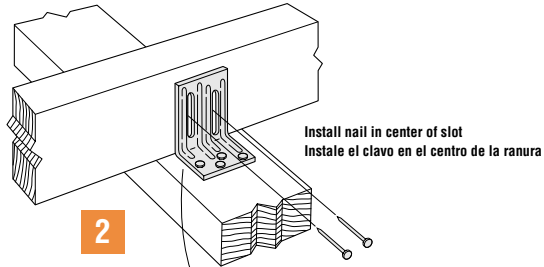
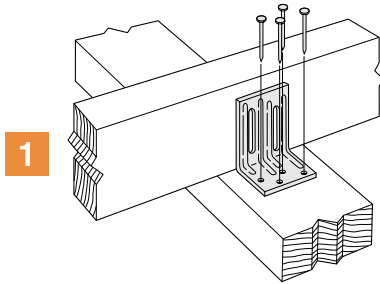

Install nail in center of slot
Instale el clavo en el centro de la ranura

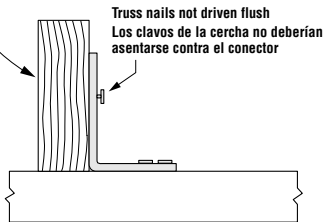

Truss nails not driven flush
Los clavos de la cercha no deberian
asentarse contra el conector

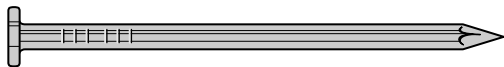

8d
(0.131" x 2½")

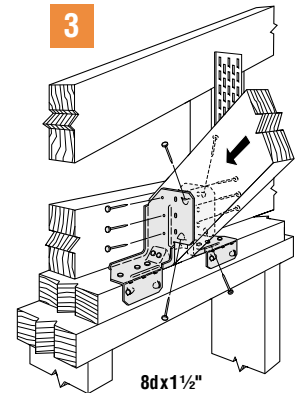
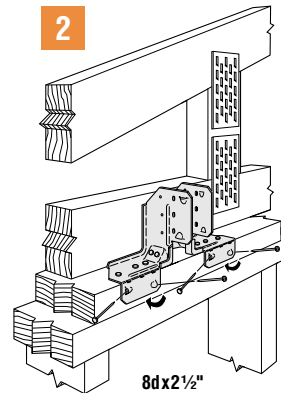
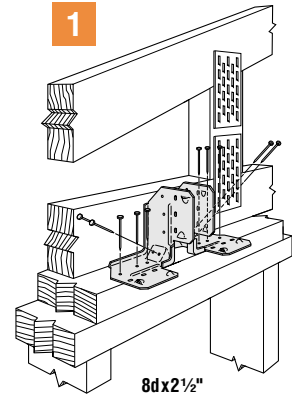
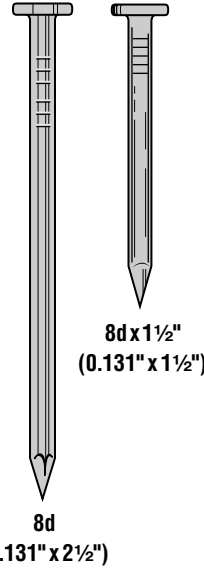

H1 – Rafter/Cabrio

SIMPSON
Strong-Tie

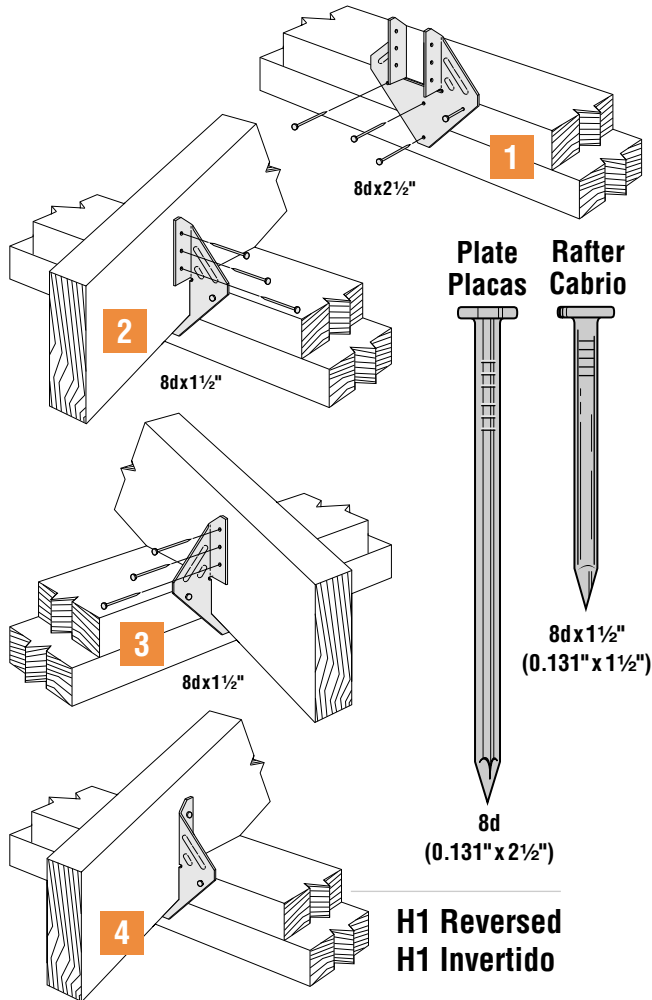

H1 – Truss/Viga

SIMPSON
Strong-Tie

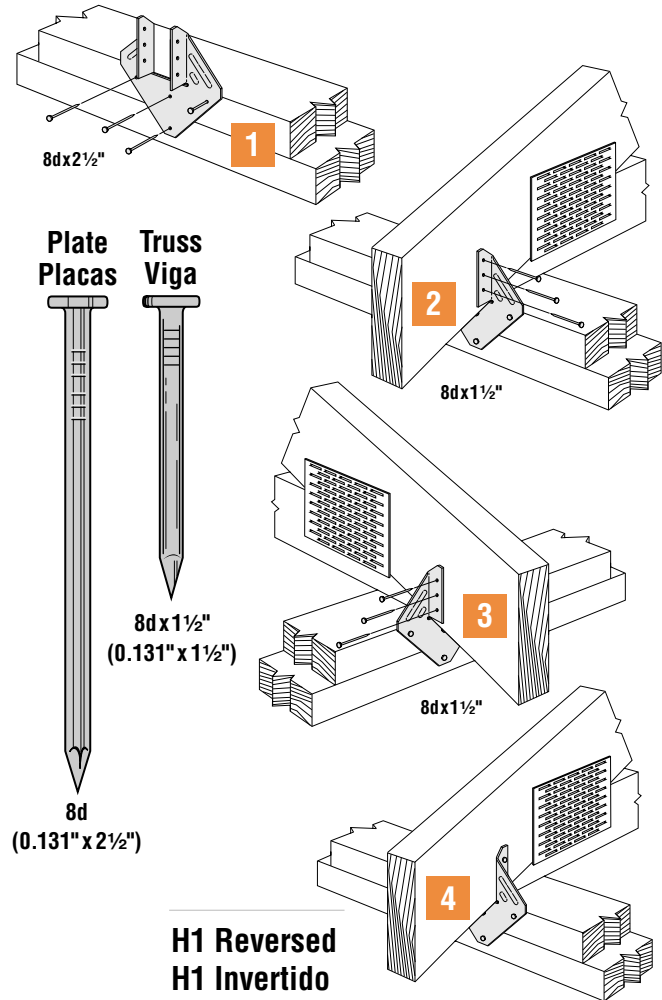

H2.5A

SIMPSON
Strong-Tie

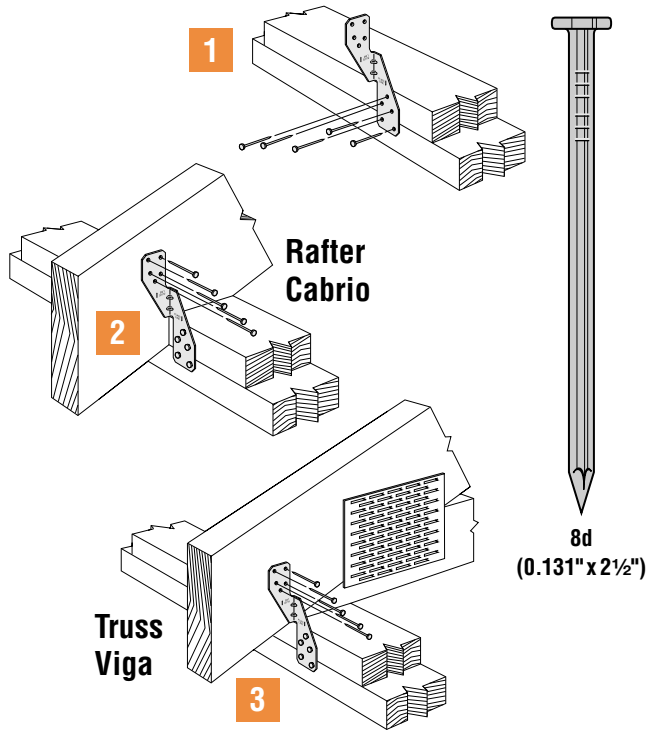

H2.5T

SIMPSON
Strong-Tie

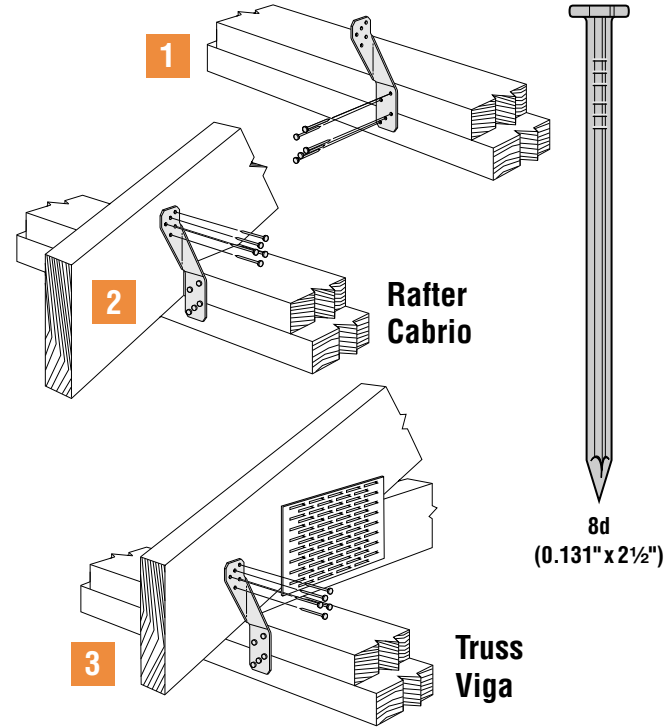

Installations in Pairs

Both connectors shall be same model.

Instalaciones en Pares

Ambos conectores deben ser del mismo modelo.

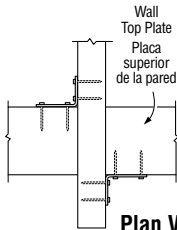

Plan View/Vista de Planta

Install diagonally across from each other for minimum 2x truss.

Instale diagonalmente uno respecto del otro para dejar una cercha de 2x como mínimo.

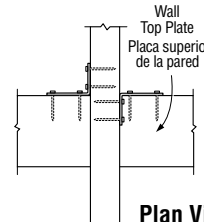

Plan View/Vista de Planta

Products can be on the same side of the wall provided they are configured as shown.

Los productos se pueden instalar a ambos lados de la pared siempre que se configuren como se muestra.

H10 – Rafter/Cabrio

SIMPSON
Strong-Tie

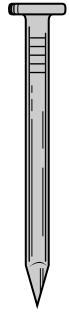

8d x 1/2"
(0.131" x 1 1/2")

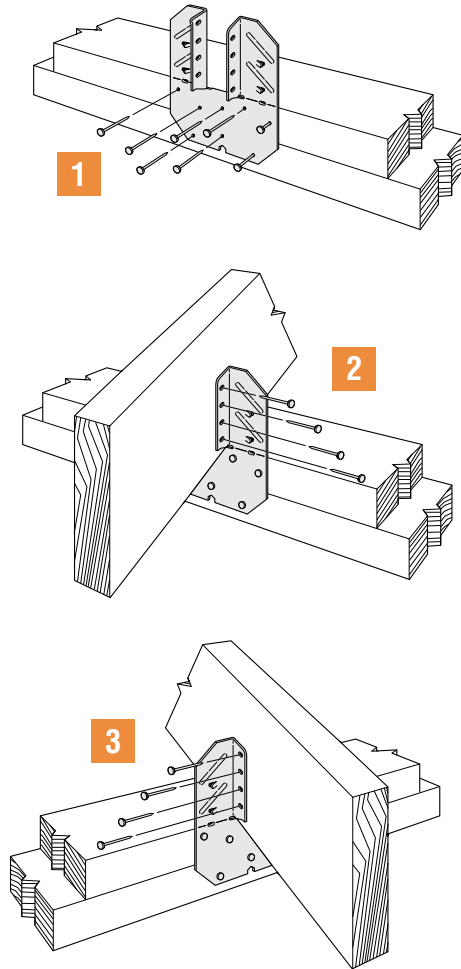

H10 – Blocking/Entramado

SIMPSON
Strong-Tie

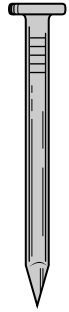

8d x 1/2"
(0.131" x 1 1/2")

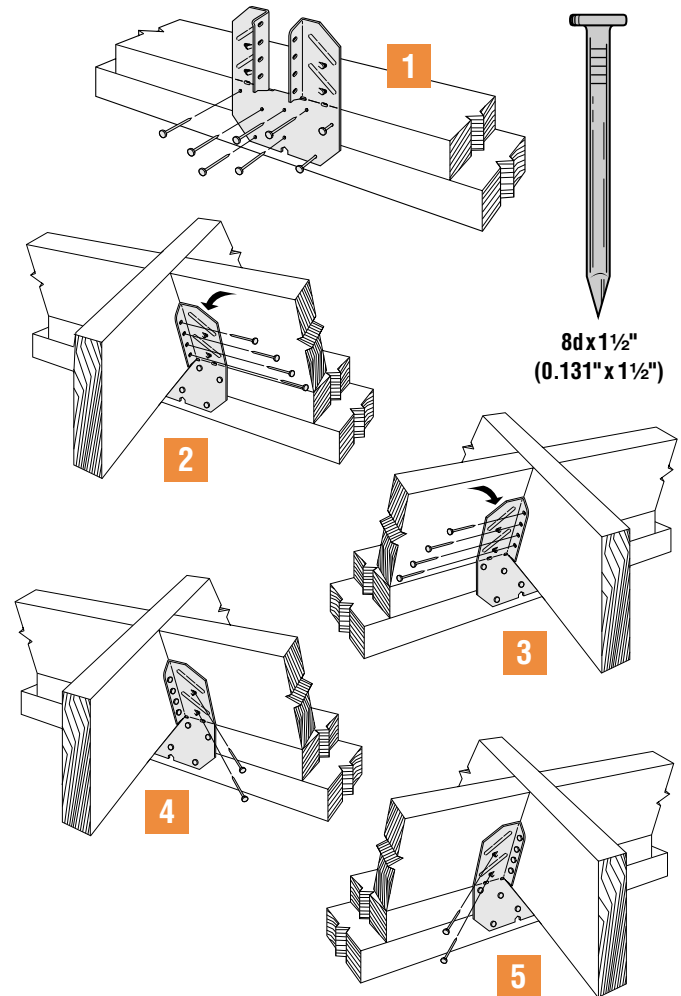

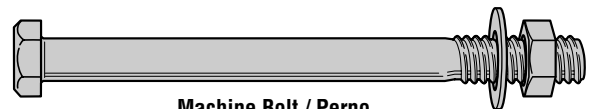
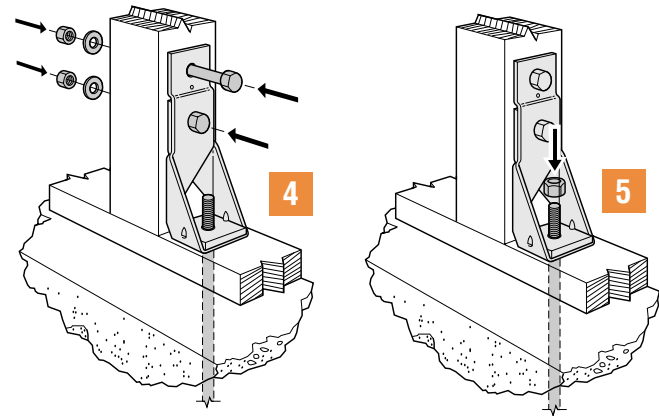
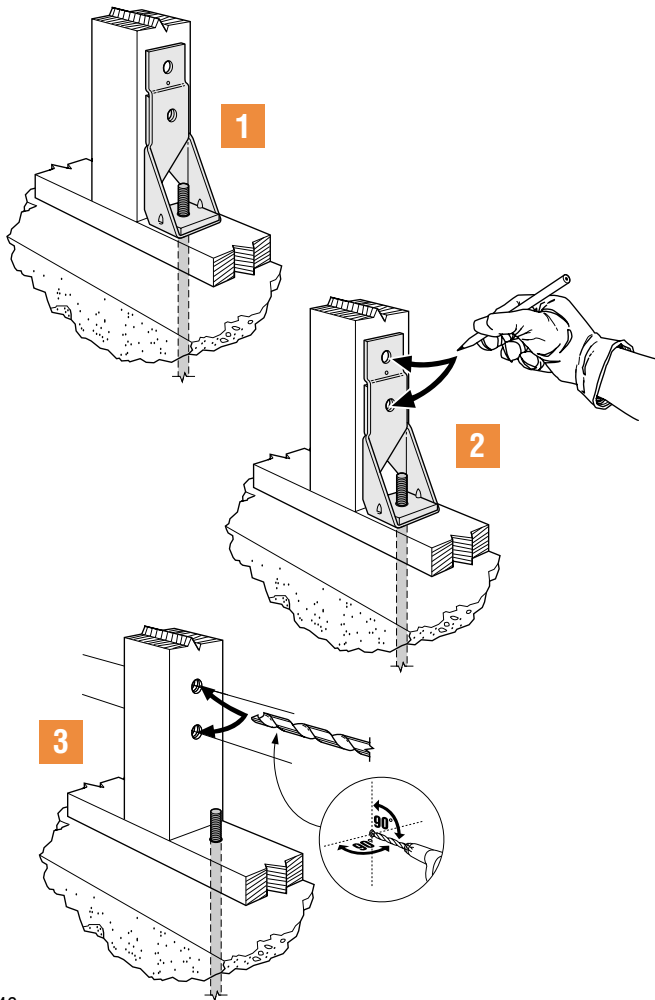

Machine Bolt / Perno

Model No./ N.º de Modelo	Machine Bolt Diameter/ Diámetro del Perno Torneado
HD2A	5/8"
HD5A	3/4"
HD6A	7/8"
HD8A	7/8"
HD10A	7/8"
HD14A	1"

Machine bolts should be at least 1" longer than wood member thickness. Bolt holes must be a minimum of 1/32" and a maximum of 1/16" larger than bolt diameter.

Los pernos torneados deben ser al menos 1" más largos que el espesor de los miembros de madera.

Los orificios para los pernos deben ser al menos 1/32" y como máximo 1/16" más grandes que el diámetro del perno.

HDQ8

SIMPSON
Strong-Tie

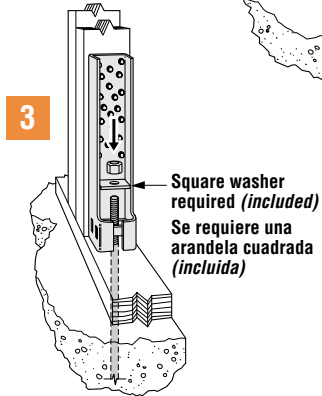
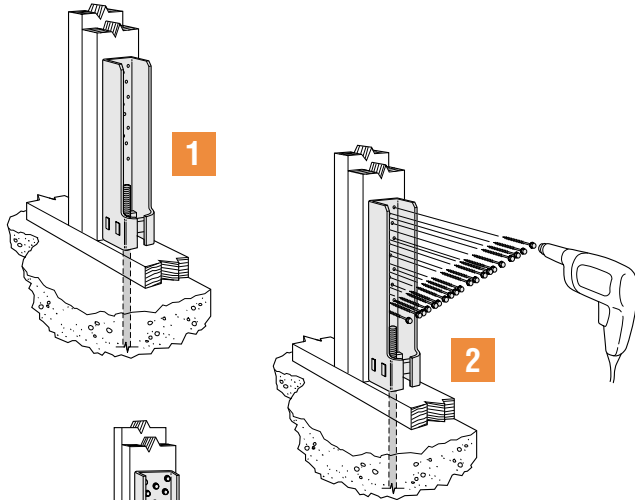

HDU

SIMPSON
Strong-Tie

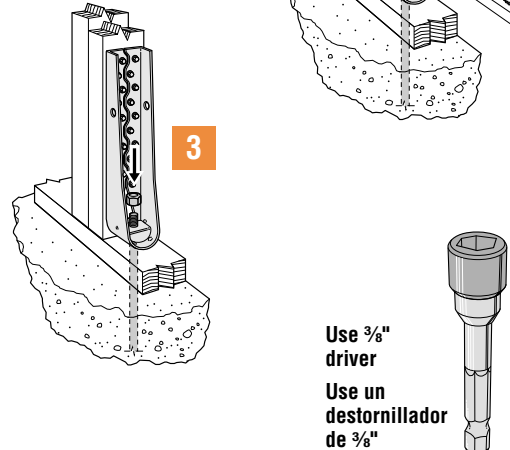
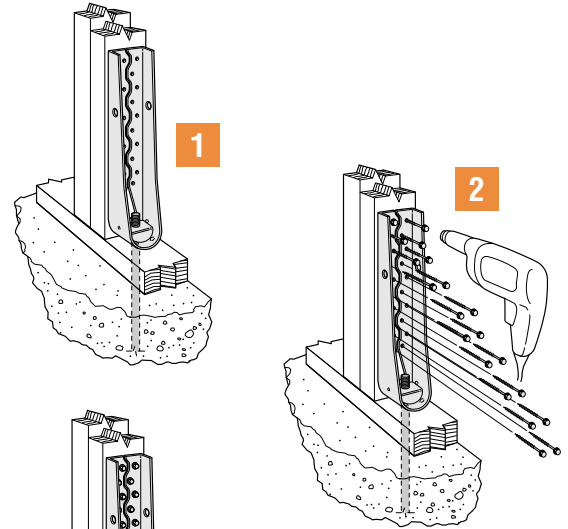

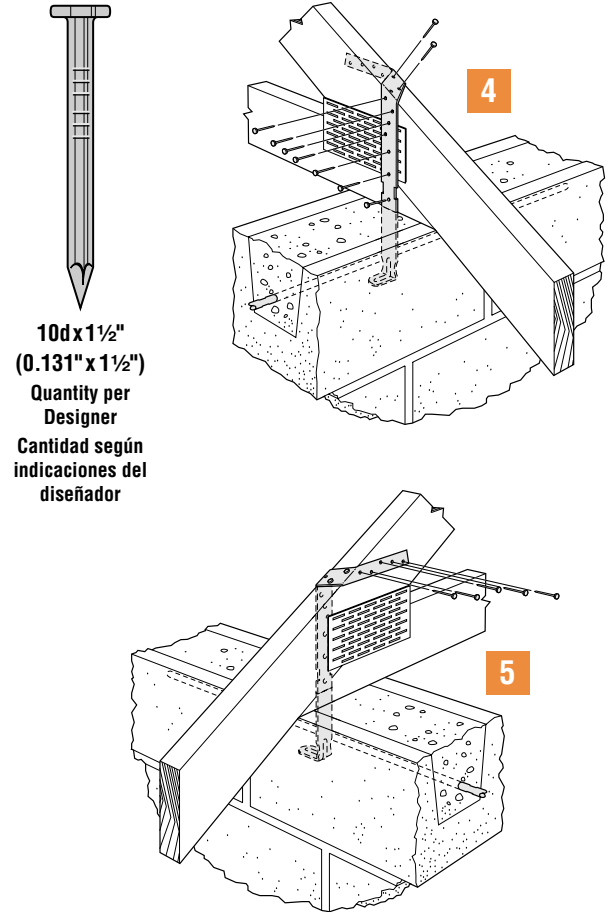
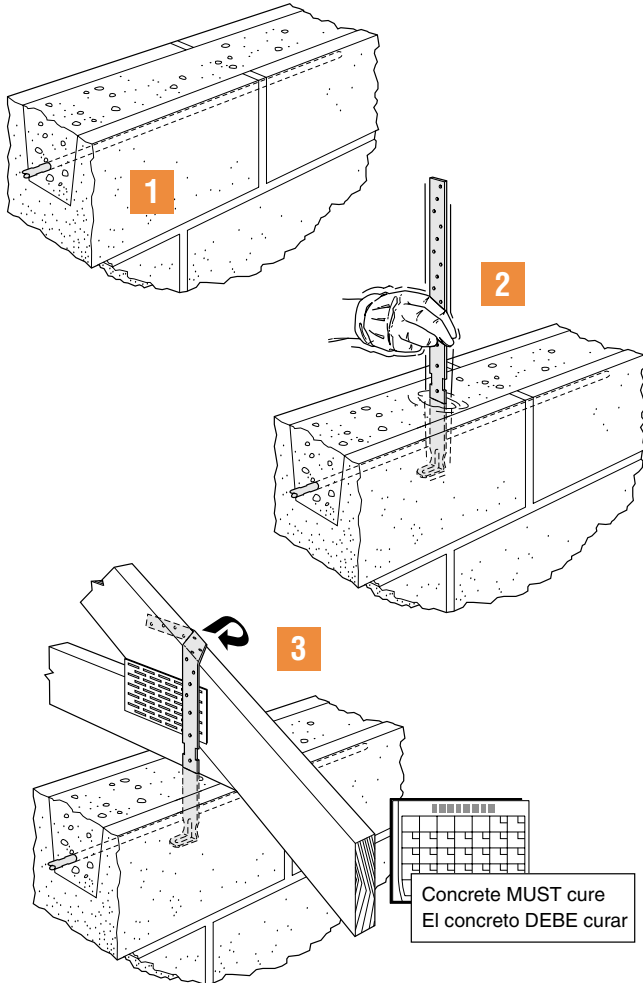

HPAHD22

SIMPSON
Strong-Tie

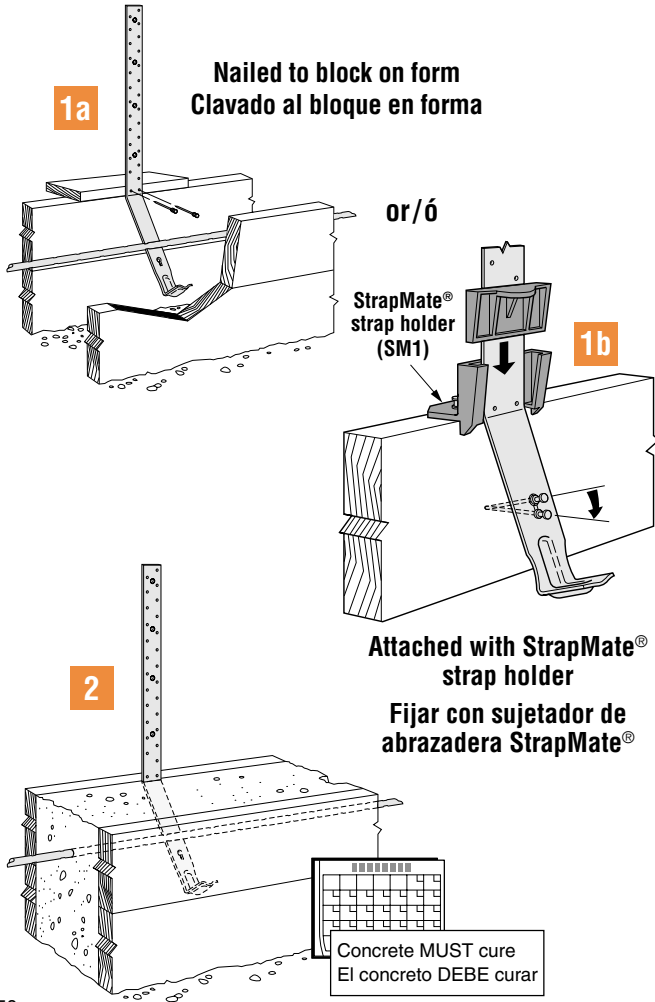

HPAHD22

SIMPSON
Strong-Tie

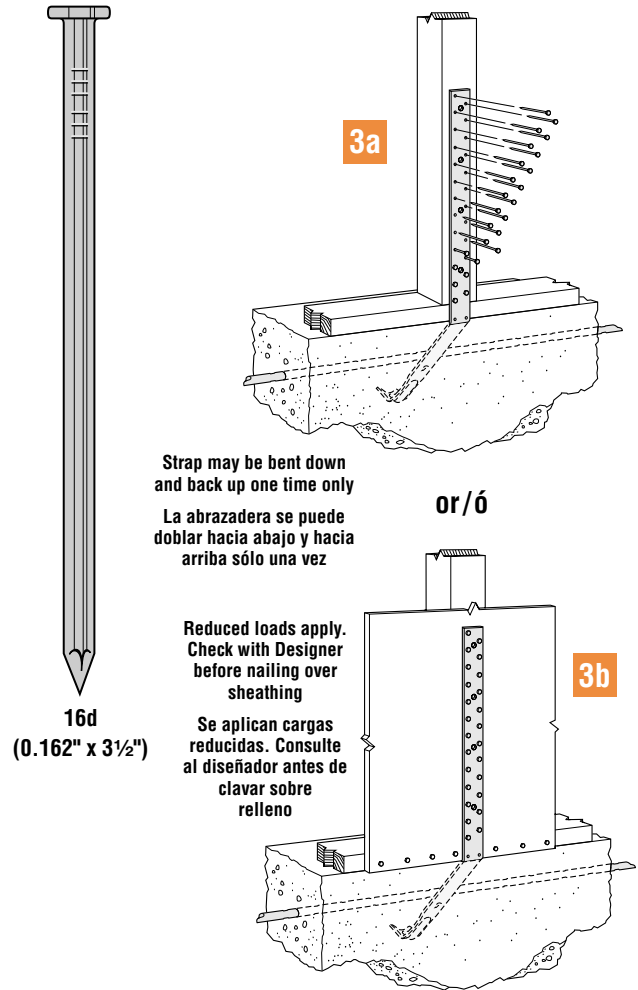

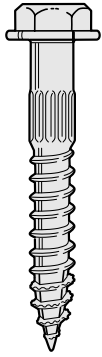

SDS 1/4" x 1 1/2"

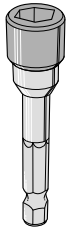

Use 3/8" driver
Use un destornillador de 3/8"

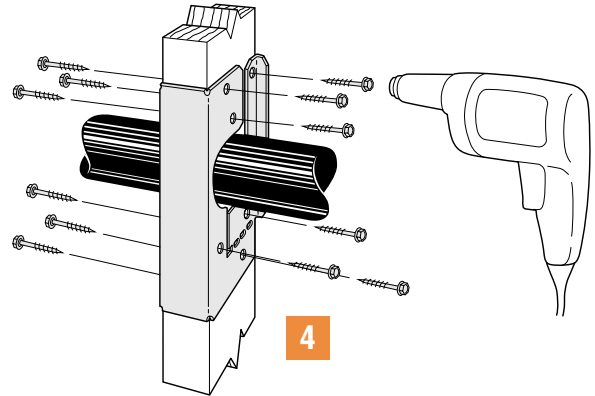
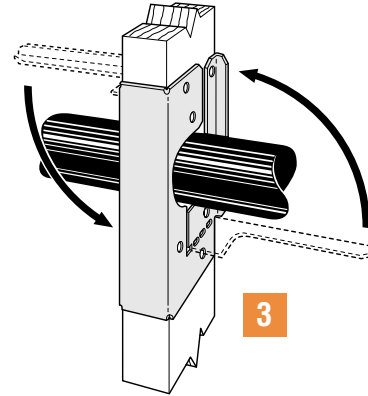
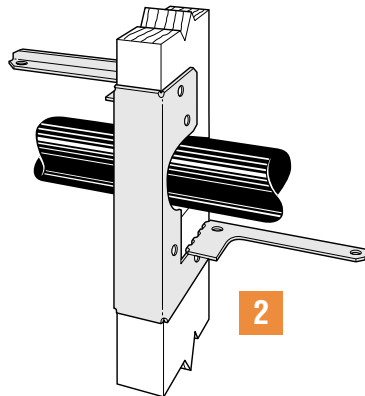
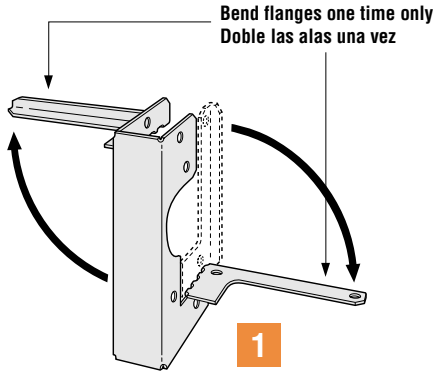

HTT

SIMPSON
Strong-Tie

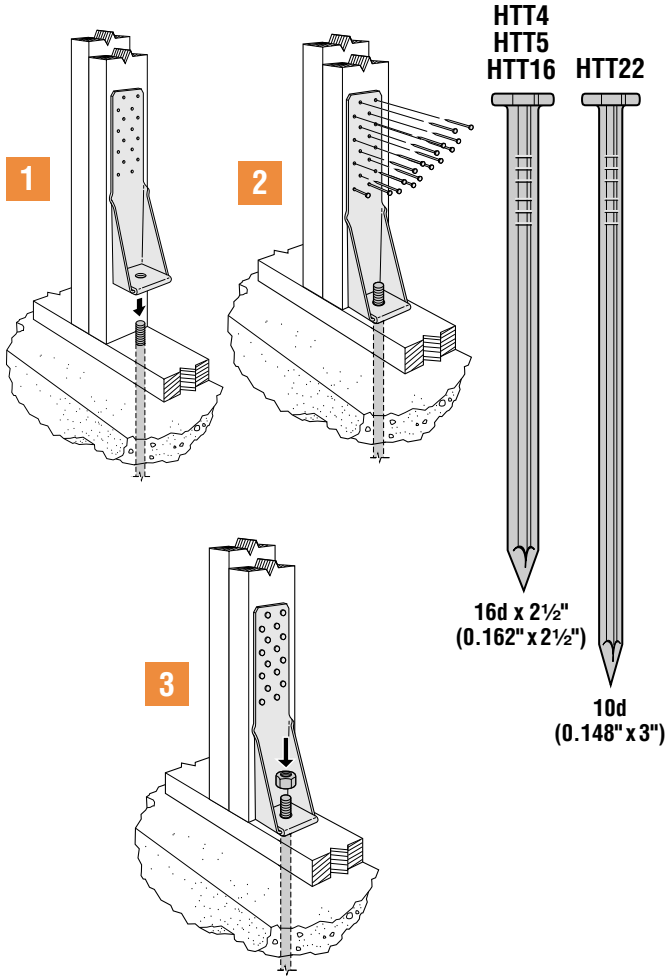

HTU

SIMPSON
Strong-Tie

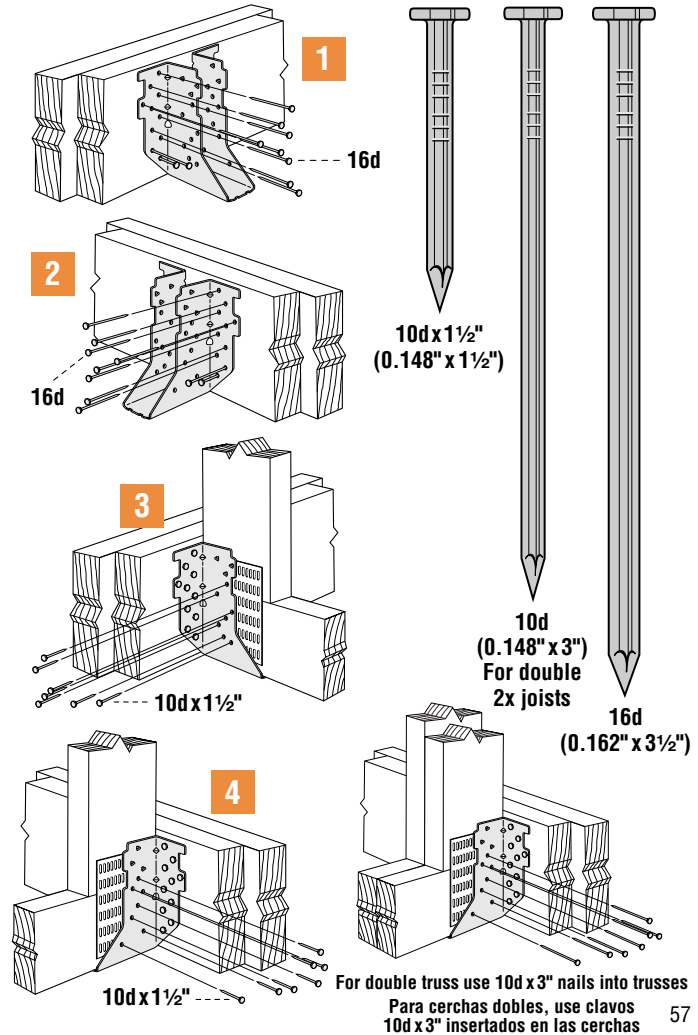

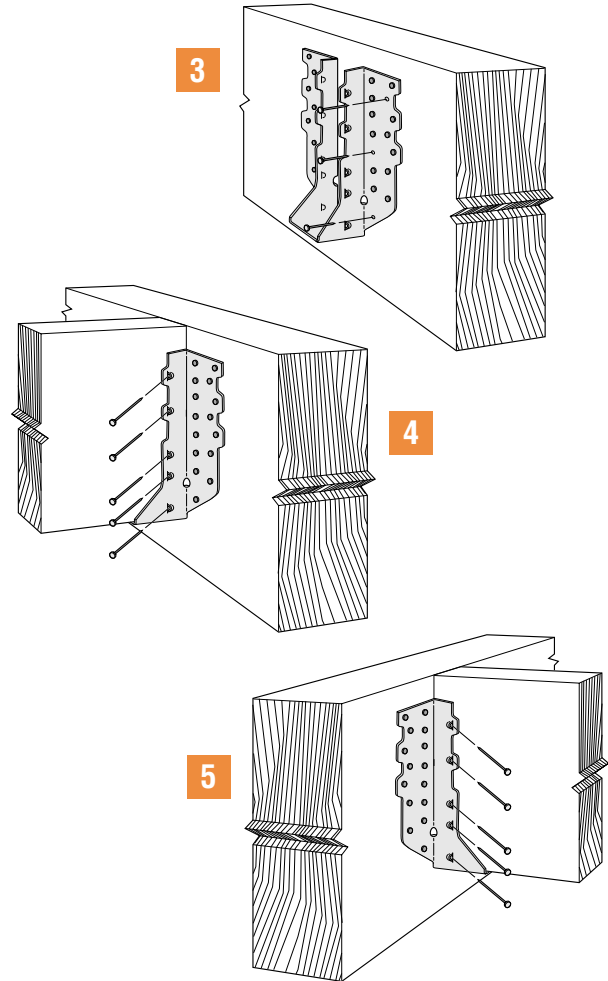
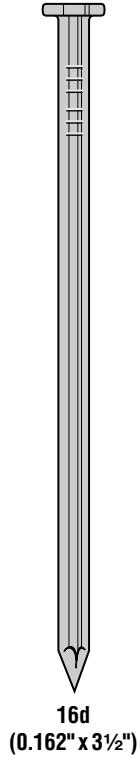
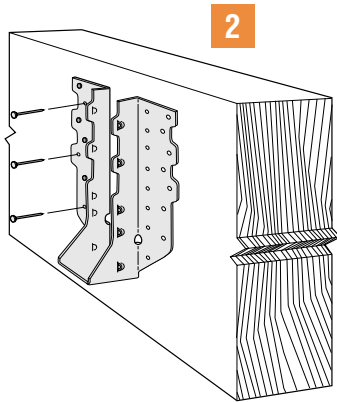
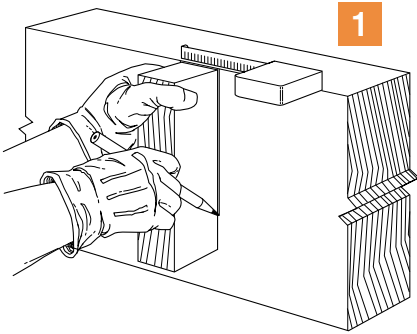

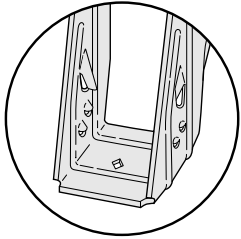

The Strong-Grip™ seat allows the I-joist to “snap” in securely – no joist nails needed.

El asiento Strong-Grip™ permite que la viga 'I' “encaje” con firmeza; no se necesitan clavos para vigas.

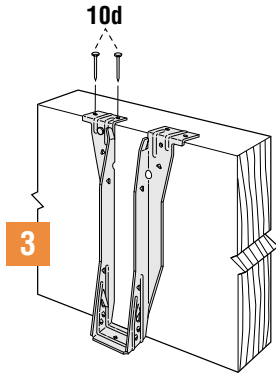
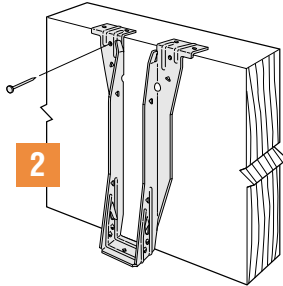
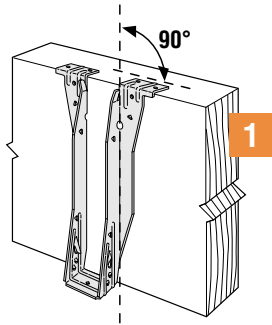

See pages 14-15 for more information.

Vea la página 14-15 para más información.



10d
(0.148" x 3")

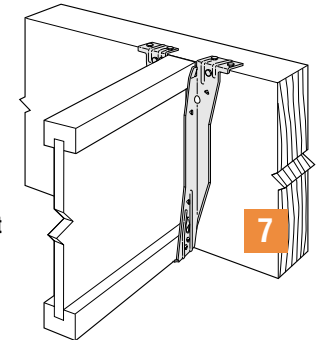
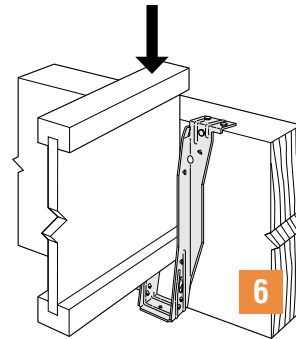
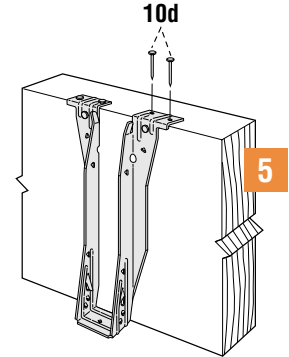
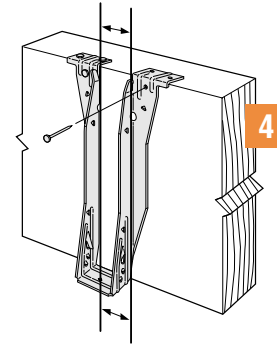

No nails required in joist
No es necesario clavar clavos en la viga

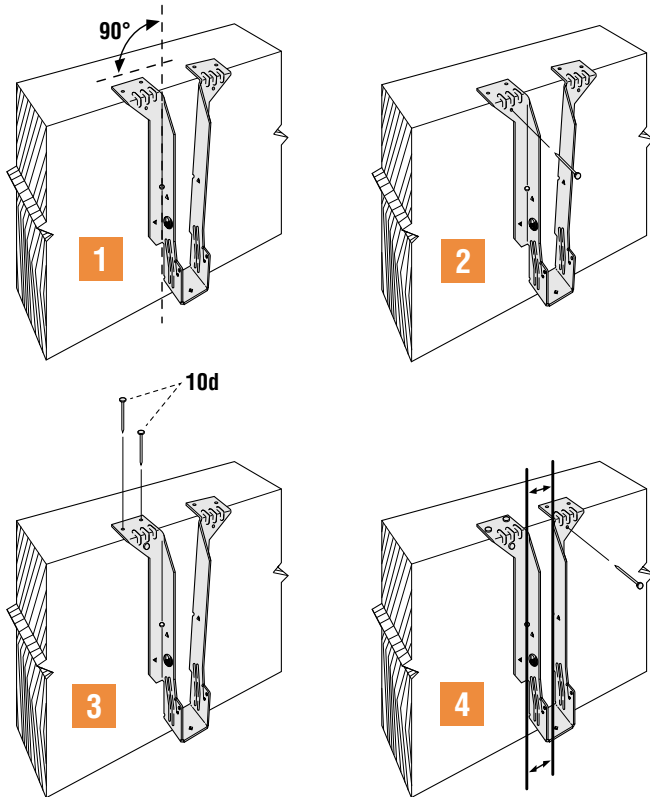

See pages 14-15 for more information.
Vea la página 14-15 para más información.



10d (0.148" x 3")
On top and face by header
Encima y en la cara de la viga cabezal

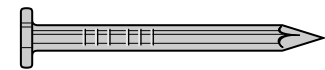
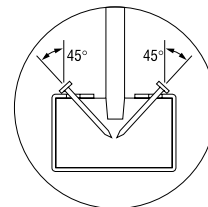
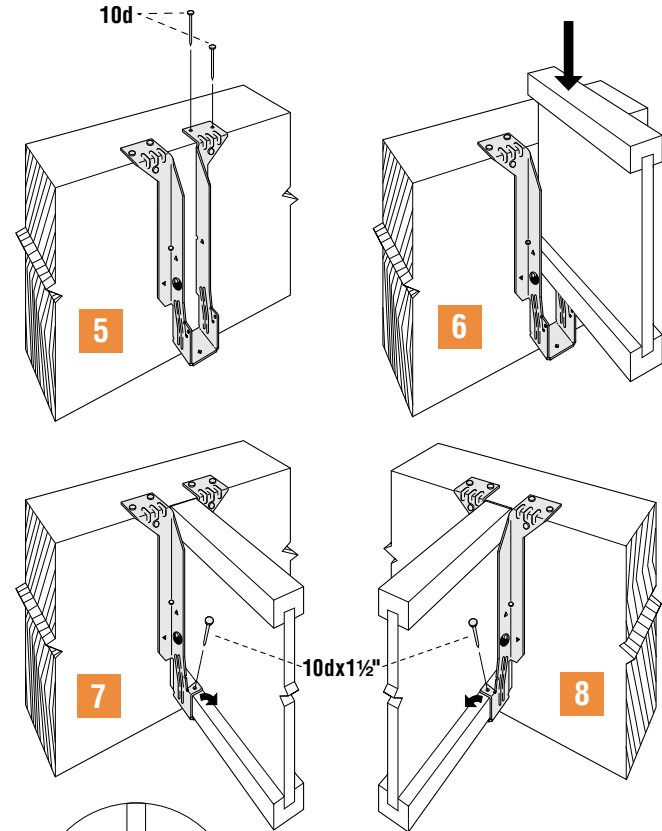

10d x 1/2" (0.148" x 1 1/2")
At joist
En la vigueta

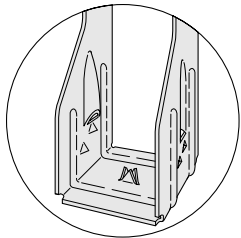

The Strong-Grip™ seat allows the I-joist to “snap” in securely – no joist nails needed.

El asiento Strong-Grip™ permite que la viga en 'I' “encaje” con firmeza; no se necesitan clavos para vigas.

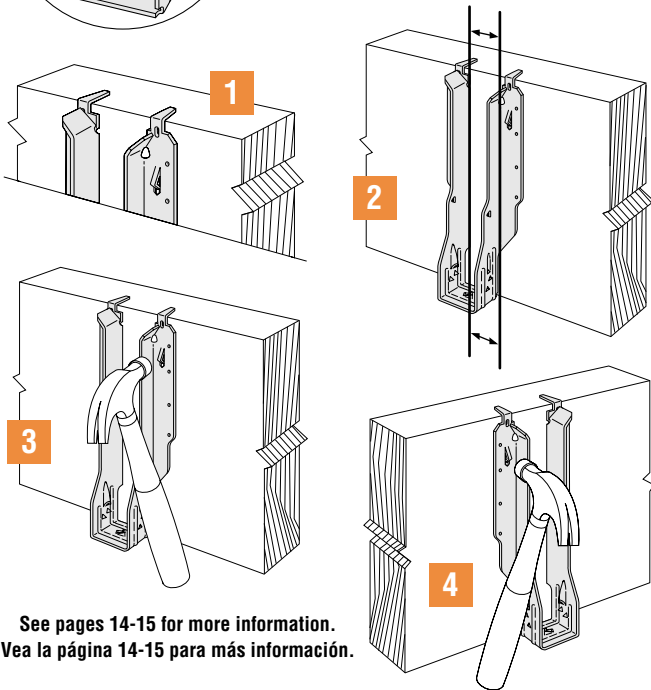

See pages 14-15 for more information.
Vea la página 14-15 para más información.



10d
(0.148" x 3")

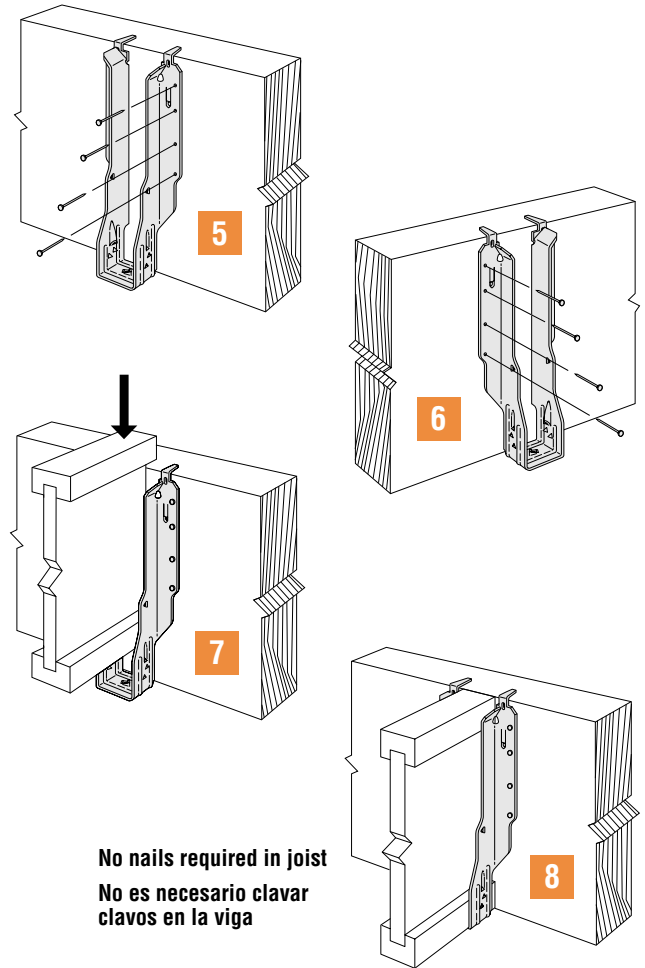

No nails required in joist
No es necesario clavar
clavos en la viga

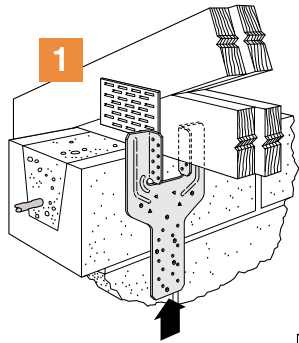

Fill  holes with
Titen® masonry screws

Llene los orificios 
con tornillos para
mampostería Titen®

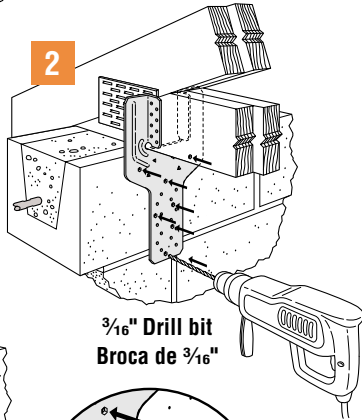

$\frac{3}{16}$ " Drill bit
Broca de $\frac{3}{16}$ "

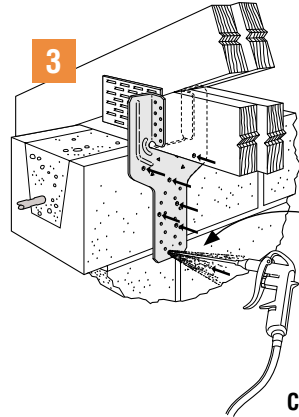

Compressed Air / Aire comprimido



Titen® Masonry Screw/Tornillo para mampostería ($\frac{1}{4}$ " x $2\frac{1}{4}$ ")
For installation in concrete use Titen $\frac{1}{4}$ " x $1\frac{3}{4}$ "
Para instalaciones en concreto, utilice Titen de $\frac{1}{4}$ " x $1\frac{3}{4}$ "

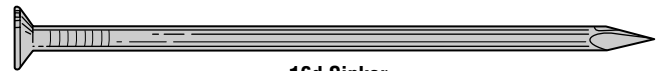
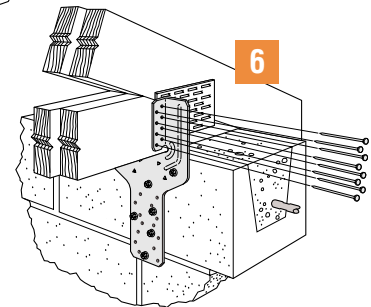
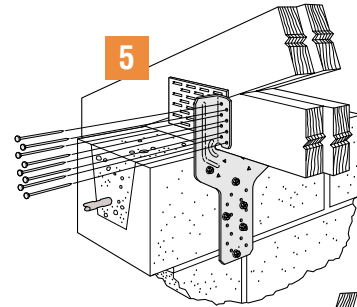
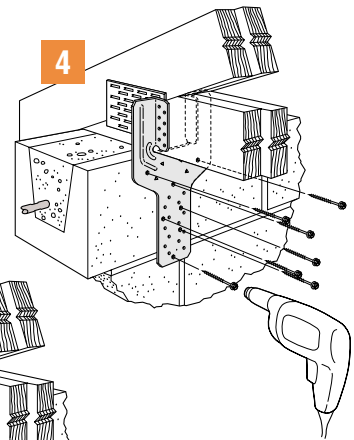

16d Sinker
(0.148 " x $3\frac{1}{4}$ ")

LS

SIMPSON
Strong-Tie

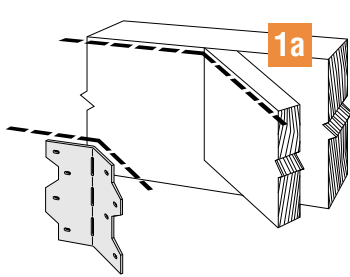

1a

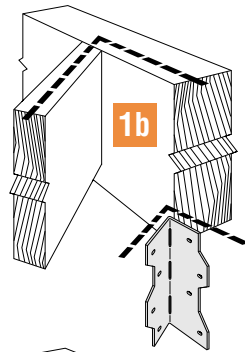

1b

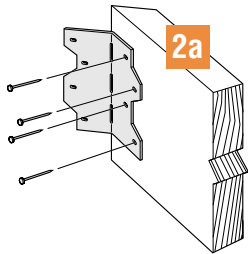

2a

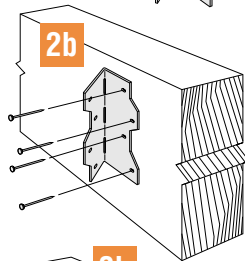

2b

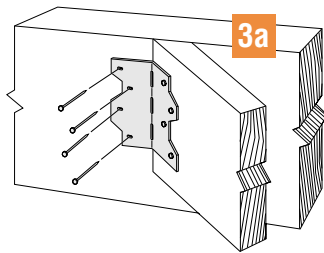

3a

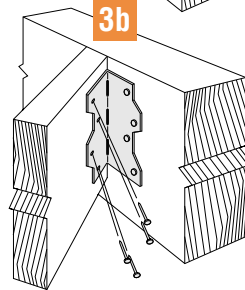

3b



10d
(0.148" x 3")

LSSU

SIMPSON
Strong-Tie

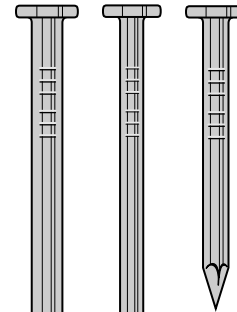

10d x 1 1/2"
(0.148" x 1 1/2")

10d
(0.148" x 3")

16d
(0.162" x 3 1/2")

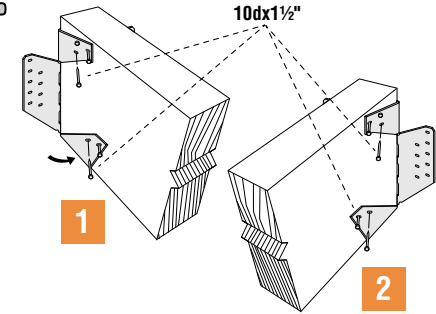

1

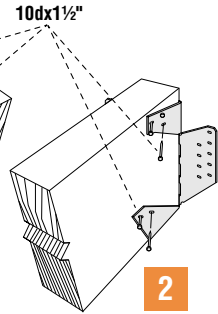

2

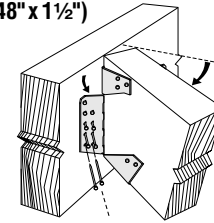

16d or/ó 10d
(See table)
(Vea la tabla)

3

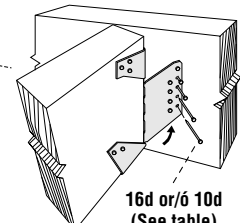

16d or/ó 10d
(See table)
(Vea la tabla)

4

Joist Width Ancho de Vigüeta	Model Modelo	Nails / Clavos	
		Face / Cara	Joist / Viga
Sloped Only Hangers / Sólo Conectores Sesgados			
1 1/2	LSSU28	10-10d	5-10dx1 1/2
1 1/2	LSSU210	10-10d	7-10dx1 1/2
2 1/2	LSSUH310	18-16d	12-10dx1 1/2
3	LSSU210-2	18-16d	12-10dx1 1/2
3 1/2	LSSU410	18-16d	12-10dx1 1/2
Skewed Hangers or Sloped and Skewed Conectores Sesgados o Con Seño y Pendiente			
1 1/2	LSSU28	9-10d	5-10dx1 1/2
1 1/2	LSSU210	9-10d	7-10dx1 1/2
2 1/2	LSSUH310	14-16d	12-10dx1 1/2
3	LSSU210-2	14-16d	12-10dx1 1/2
3 1/2	LSSU410	14-16d	12-10dx1 1/2

LSTA

SIMPSON
Strong-Tie

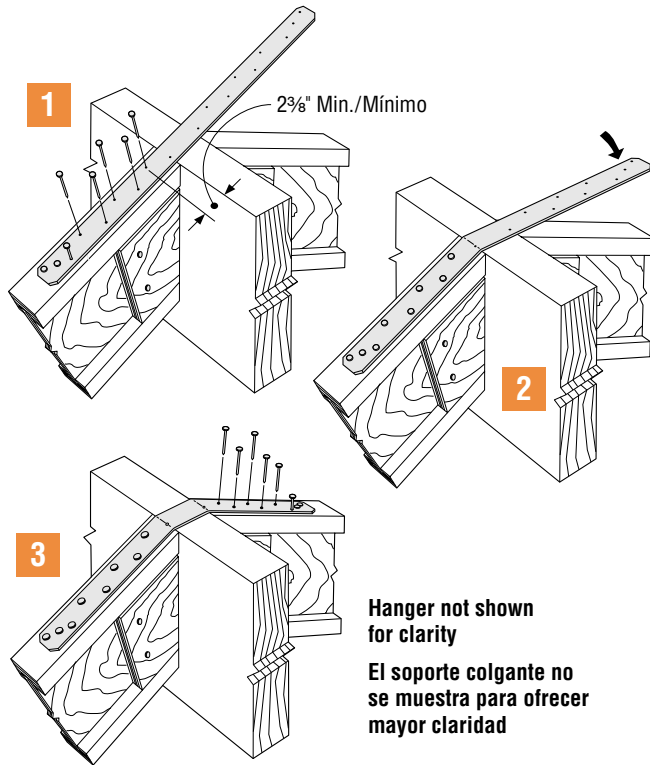

For I-joist installation only
Sólo para instalación de vigas en 'I'

LTHJR

SIMPSON
Strong-Tie

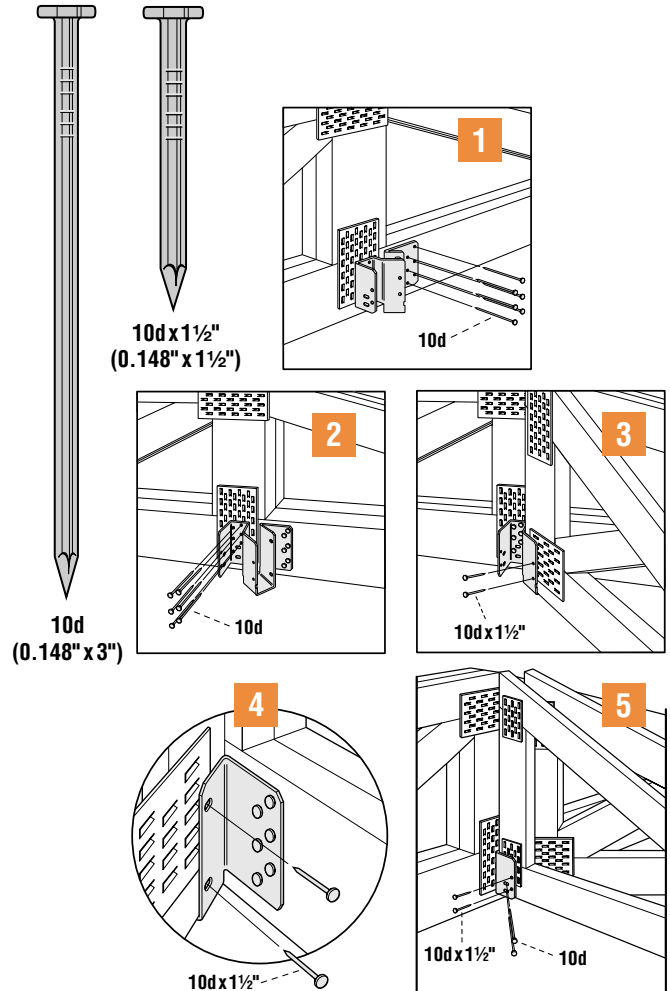

LTP4/LTP5

SIMPSON
Strong-Tie

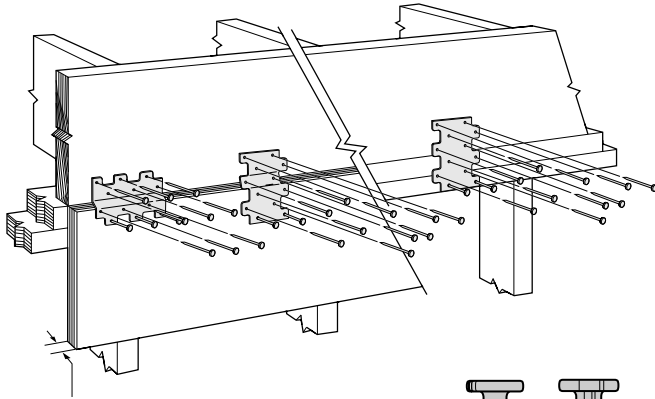

Fasteners:

LTP4

No sheathing: 8dx1½"
Over sheathing (¾" thick max.): 8dx2½"

LTP5

No sheathing: 8dx1½"
Over sheathing (½" thick max.): 8dx2½"

Sujetadores:

LTP4

Sin relleno: 8dx1½"
Sobre relleno (¾" de espesor máx.): 8dx2½" (0.131" x 1½")

LTP5

Sin relleno: 8dx1½"
Sobre relleno (½" de espesor máx.): 8dx2½"

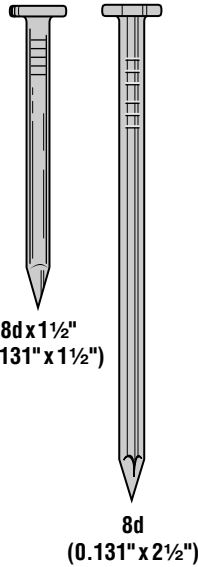

LUC2

SIMPSON
Strong-Tie

Header
Viga cabezal

Joist
Viga

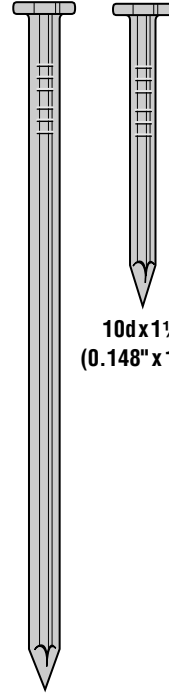

16d
(0.162" x 3½")

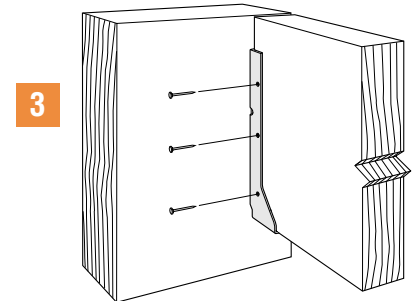
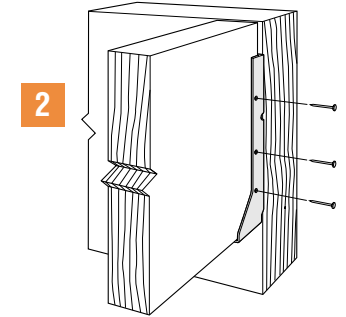
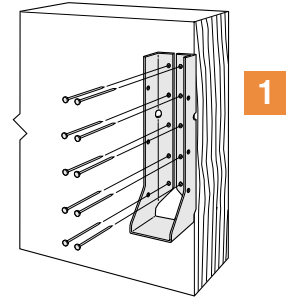

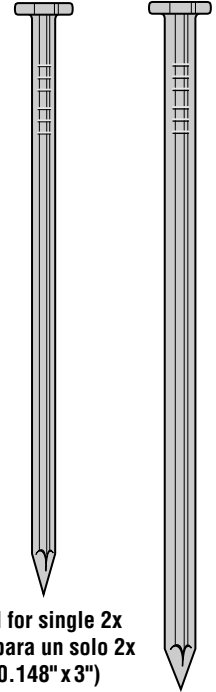
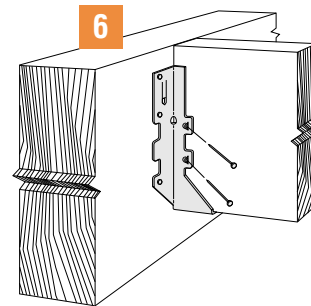
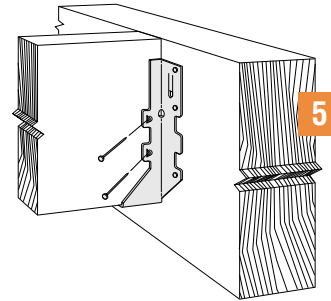
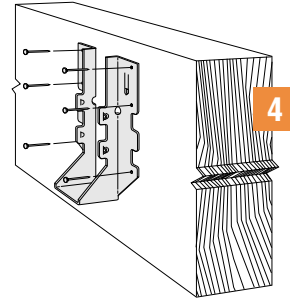
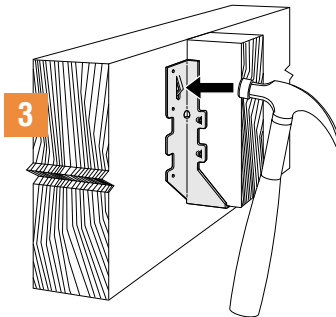
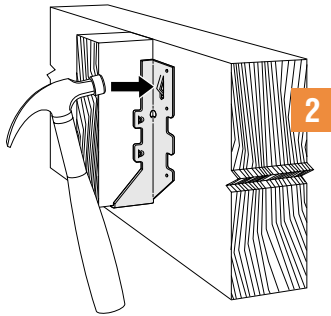
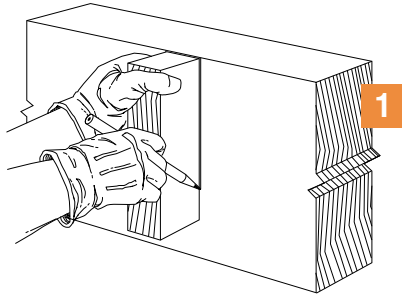

10d for single 2x
10d para un solo 2x
(0.148" x 3")

16d for all others
16d para los demás
(0.162" x 3½")

MA

SIMPSON
Strong-Tie

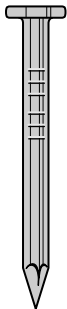
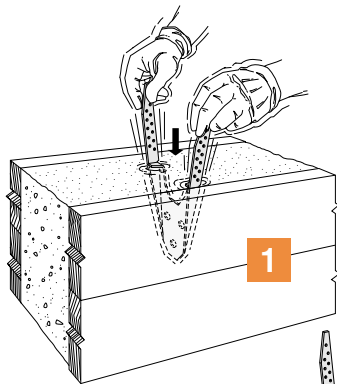

10d x 1 1/2"
(0.148" x 1 1/2")

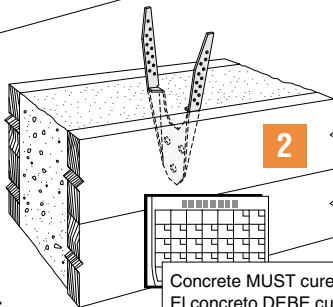

Concrete MUST cure
El concreto DEBE curar

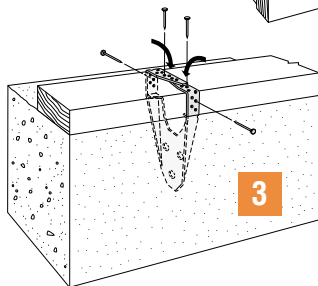

Stud installation similar
Similar a la instalación en montantes

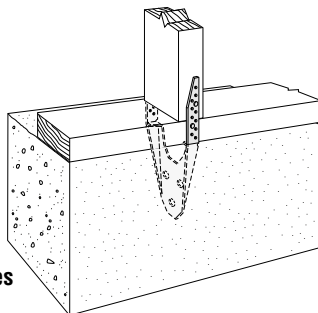

MAB – Block/Bloque

SIMPSON
Strong-Tie

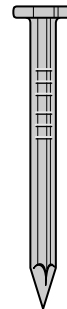
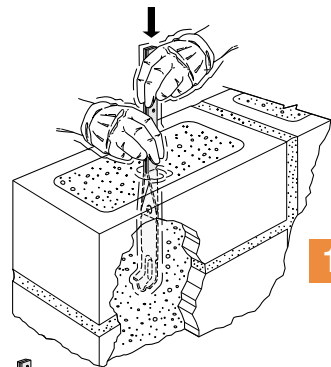

10d x 1 1/2"
(0.148" x 1 1/2")

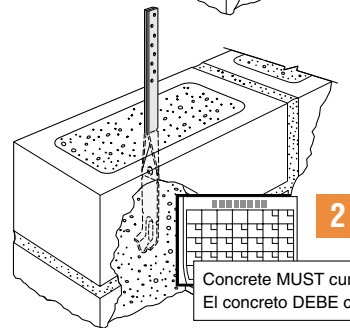

Concrete MUST cure
El concreto DEBE curar

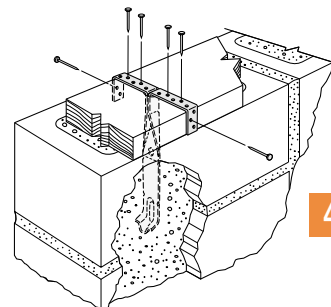
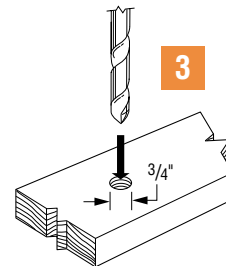

MAB – Concrete/Concreto

SIMPSON
Strong-Tie

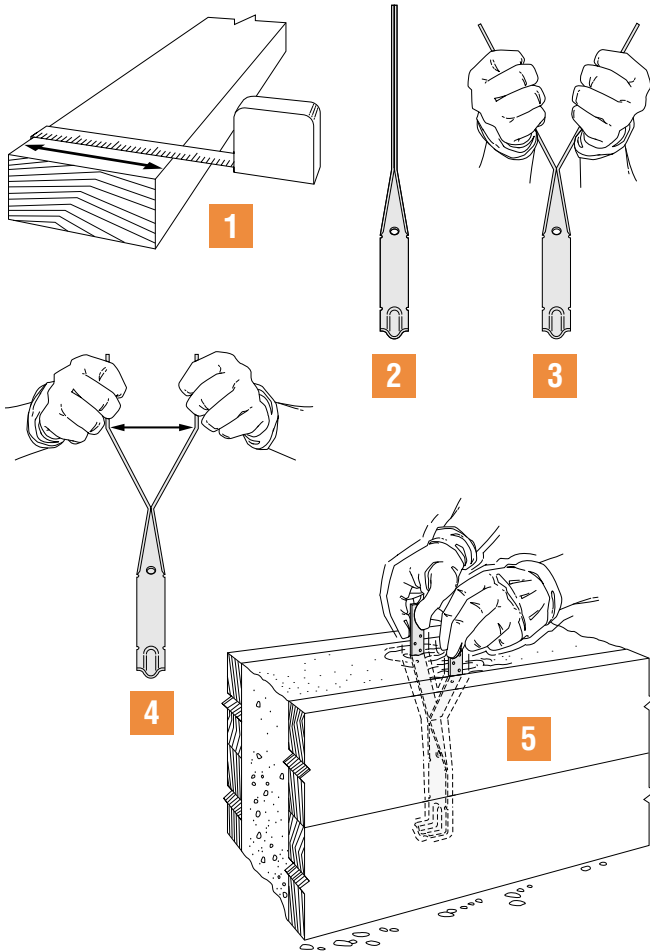

MAB – Concrete/Concreto

SIMPSON
Strong-Tie

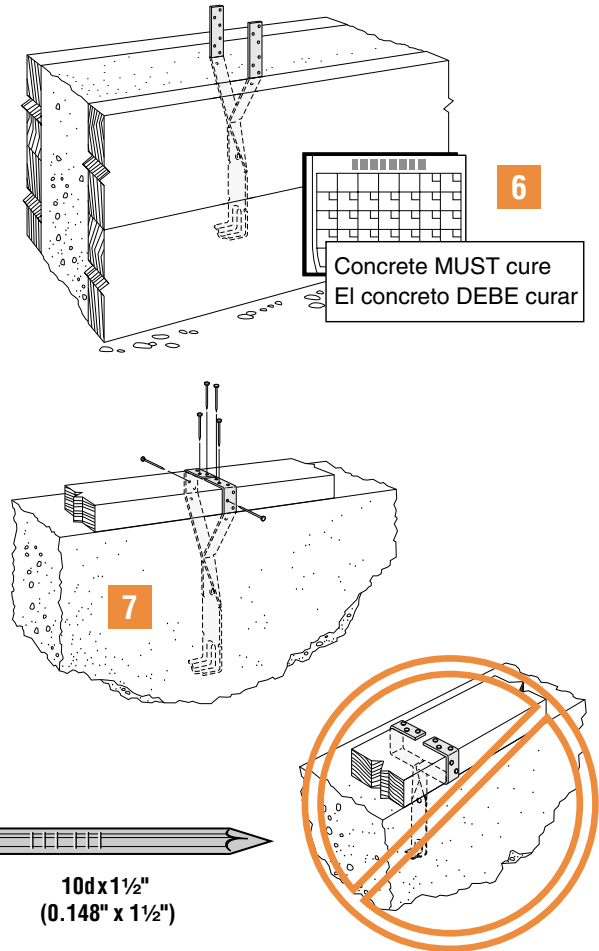

MASA/MAS

SIMPSON
Strong-Tie

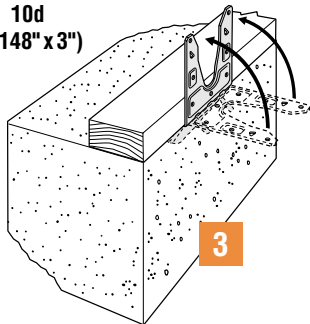
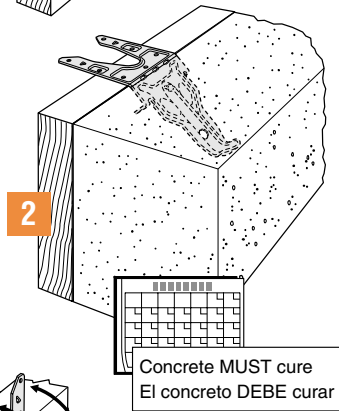
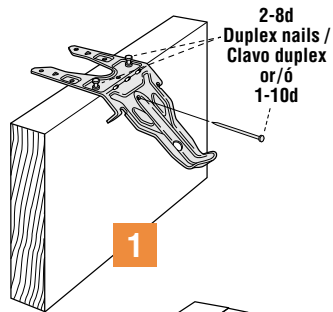
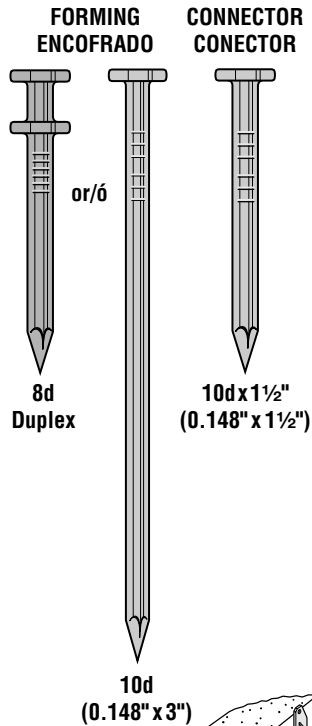

MASA/MAS

SIMPSON
Strong-Tie

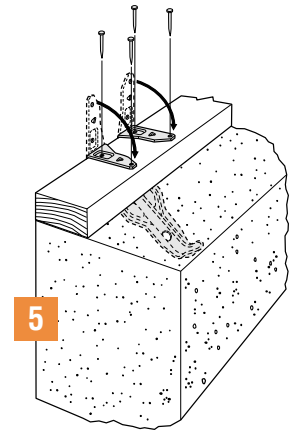
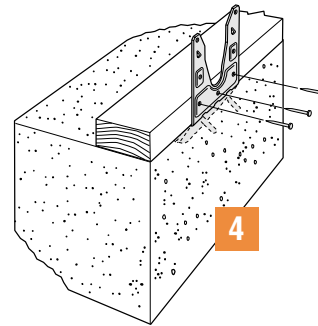

Option 1
Opción 1

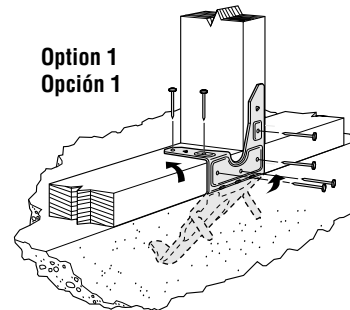

Reduced loads apply, check with Designer
Se aplican cargas reducidas; consulte al diseñador

Blocking required attached to sill with A35Z (not shown) or per Designer

Se debe adjuntar un bloqueo al larguero con A35Z (no se muestra) o según indicaciones del diseñador

Option 2
Opción 2

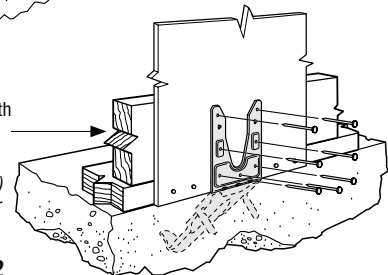

Reduced loads apply, check with Designer before nailing over sheathing
Se aplican cargas reducidas; consulte al diseñador antes de clavar sobre el relleno

MASA/MAS

SIMPSON
Strong-Tie

Brick-Ledge Installation Instalación Sobre Cornisa de Ladrillos

2-8d Duplex nails / Clavo duplex or/ó 1-10d

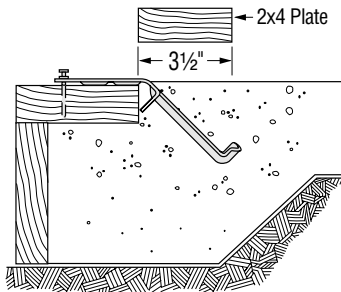
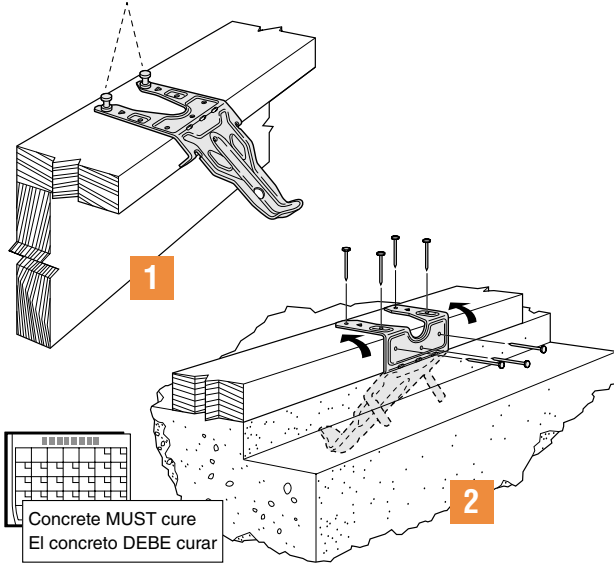

MASA/MAS

SIMPSON
Strong-Tie

Inside-the-Mudsill Installation Instalación en Solera

2-8d Duplex nails / Clavo duplex or/ó 1-10d

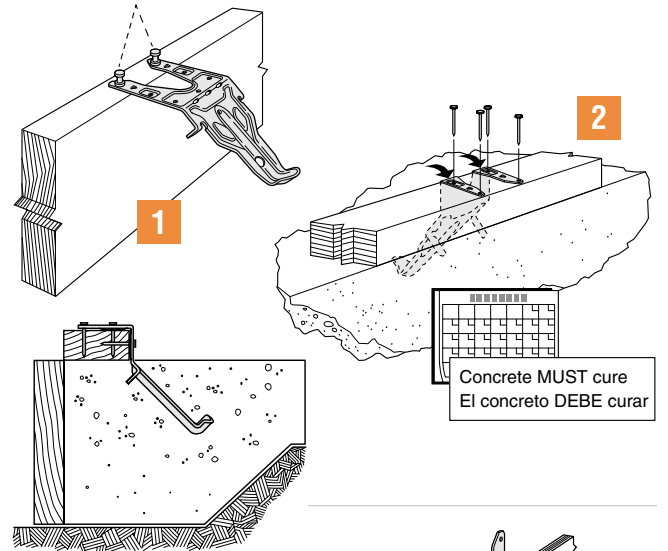

MASAP/MASP
Similar / Similar

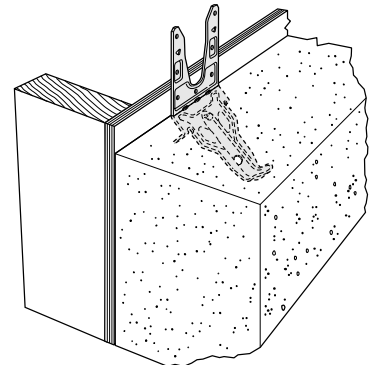

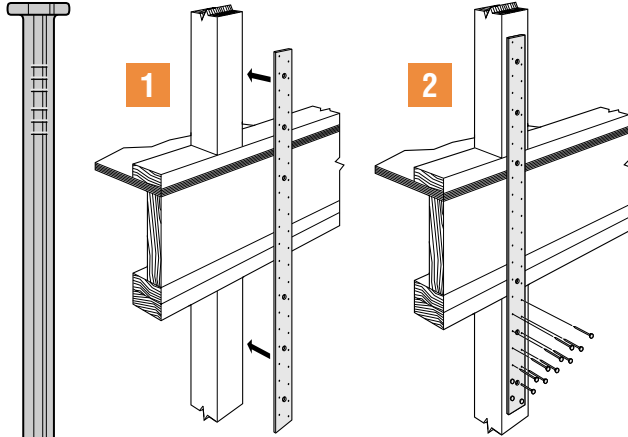

No sheathing / Sin relleno

16d
(0.162" x 3½")

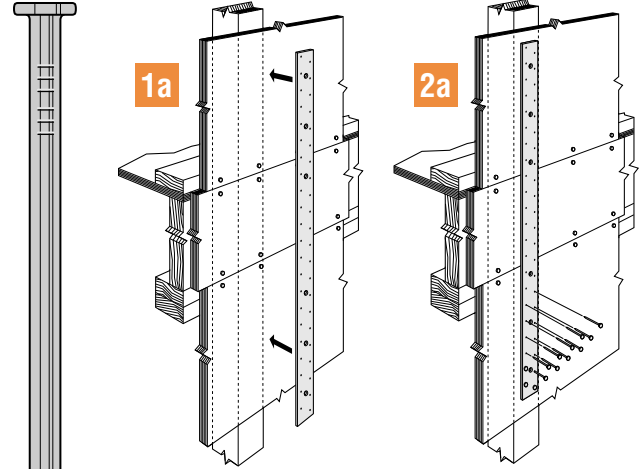
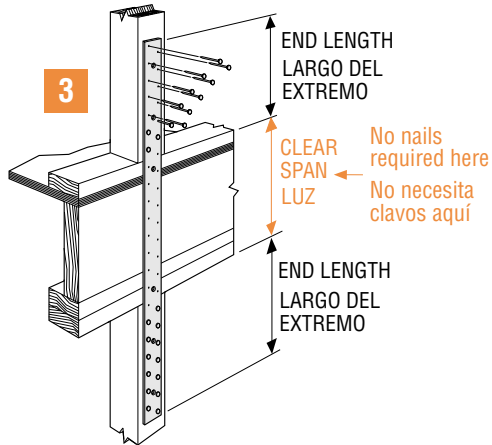

With sheathing / Con relleno

16d
(0.162" x 3½")

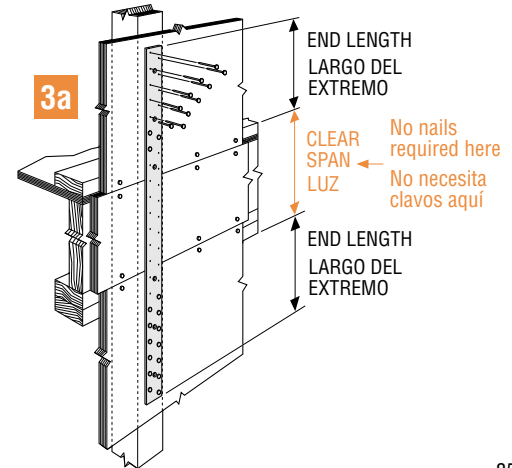

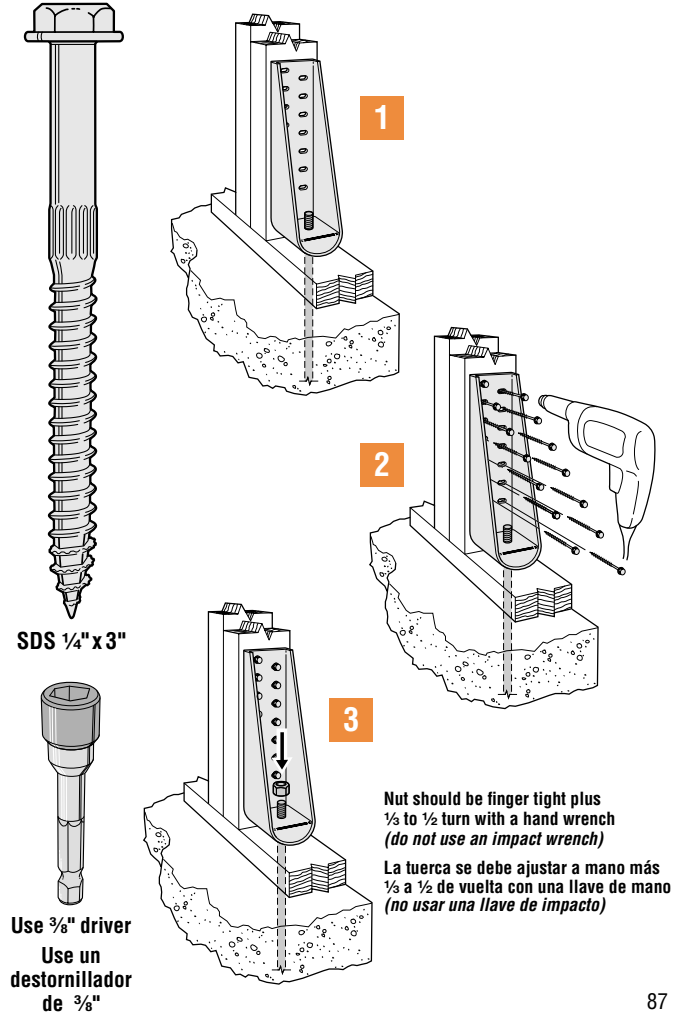
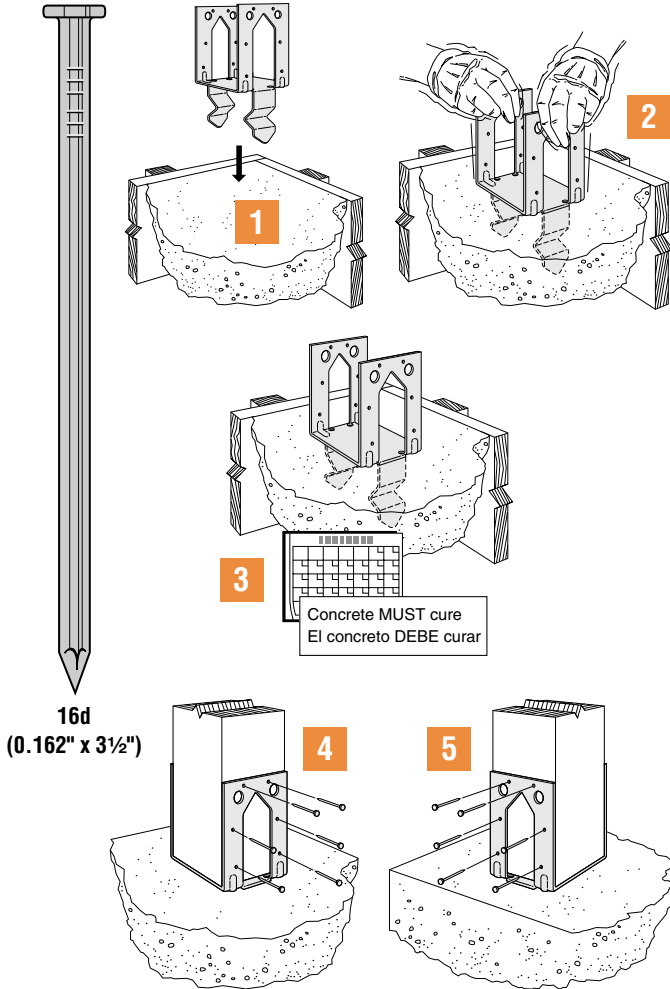

PSPN

SIMPSON
Strong-Tie

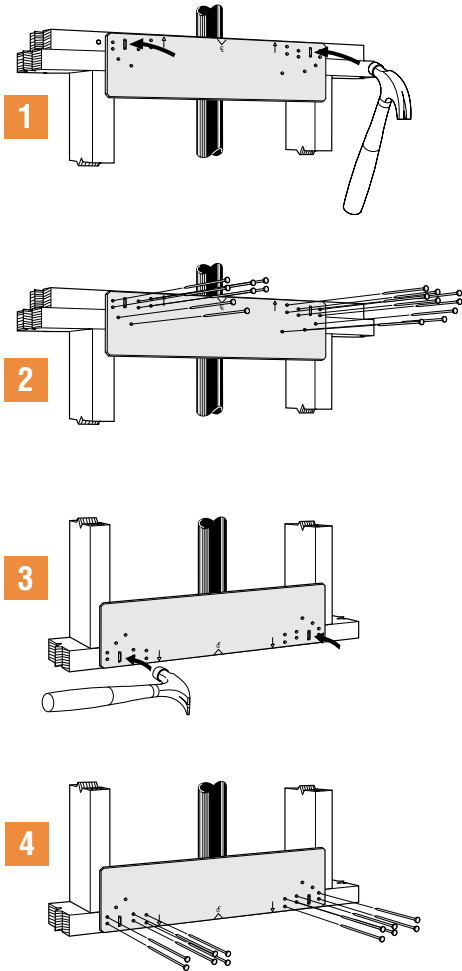
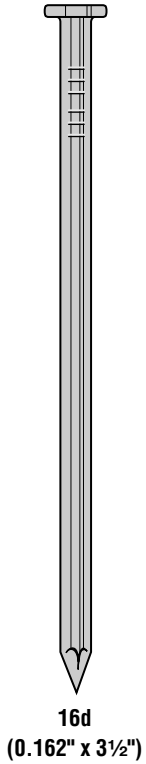

RBC

SIMPSON
Strong-Tie

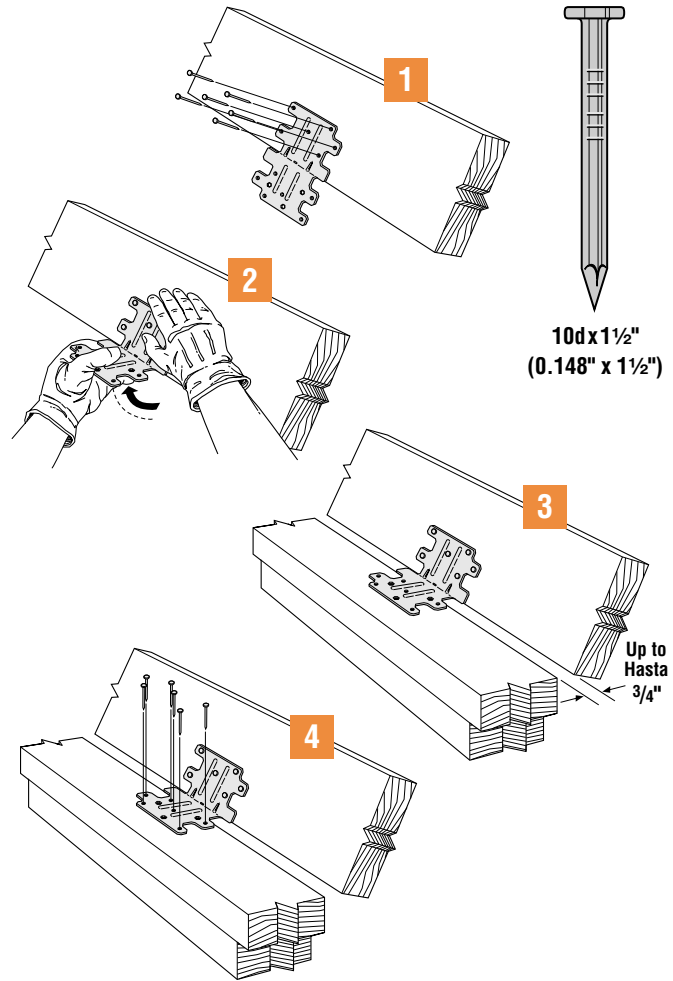

RSP4

SIMPSON
Strong-Tie

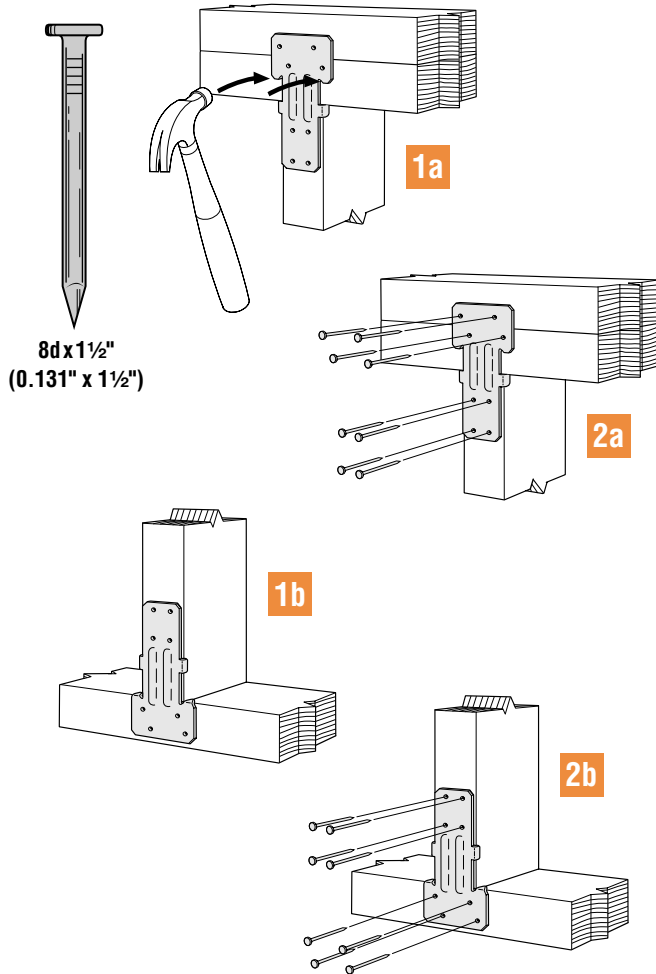

SB

SIMPSON
Strong-Tie

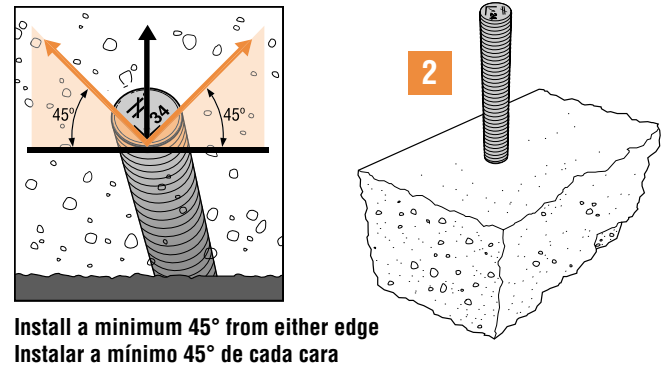
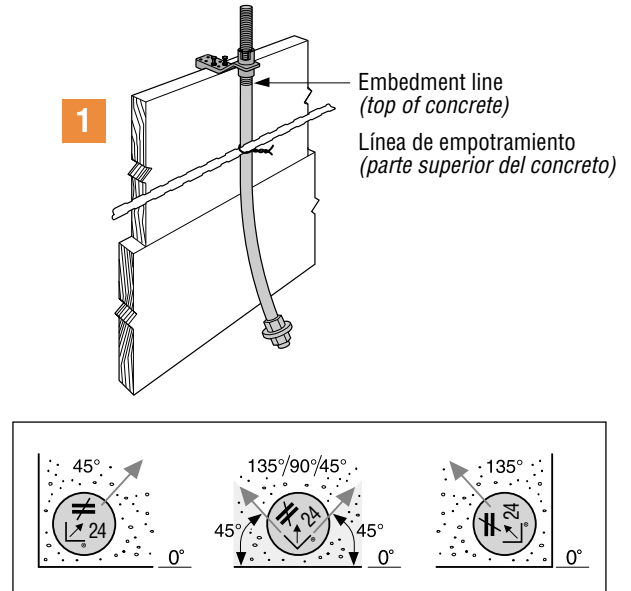

SP

SIMPSON
Strong-Tie

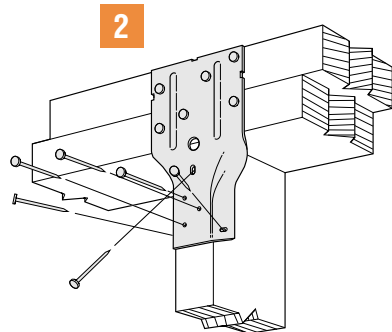
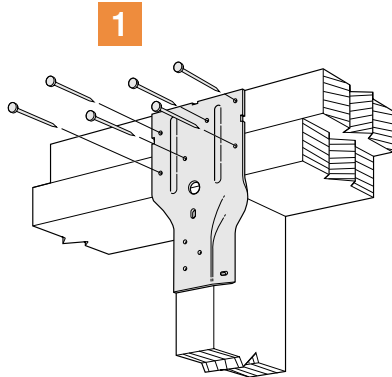
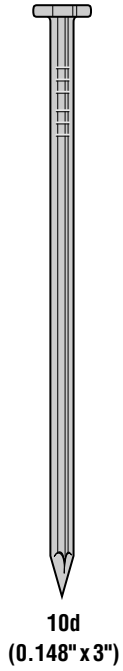

SP4

SIMPSON
Strong-Tie

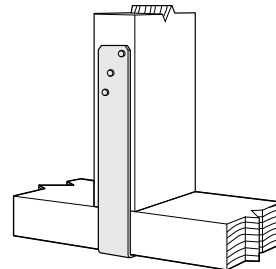
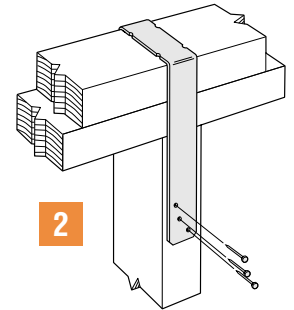
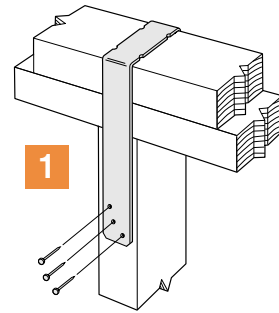
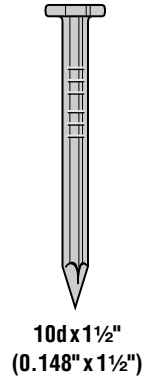

**Installation on mudsill/bottom
plate similar**

**Instalación en solera/similar a la
placa inferior**

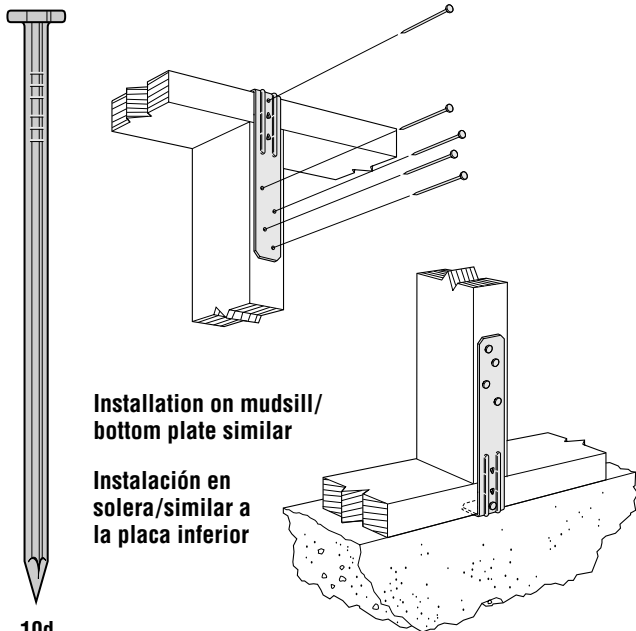

Installation on mudsill/
bottom plate similar

Instalación en
solera/similar a
la placa inferior

10d
(0.148" x 3")

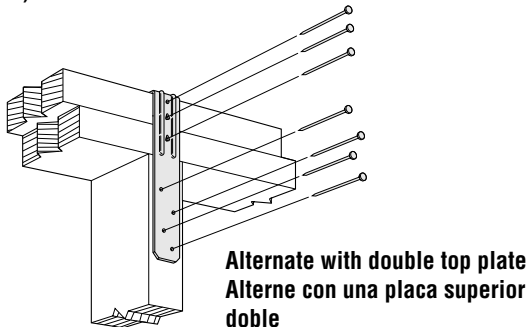

Alternate with double top plate
Alternar con una placa superior
doble

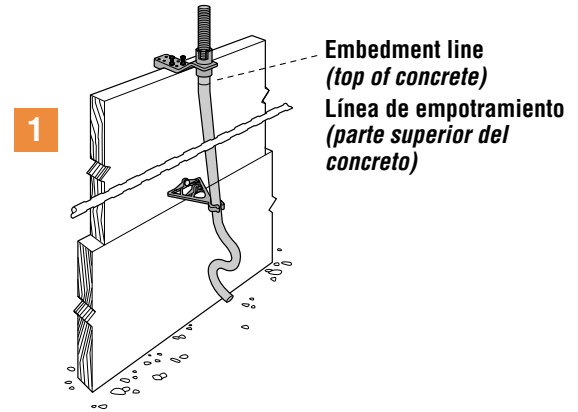

Embedment line
(top of concrete)
Línea de empotramiento
(parte superior del
concreto)

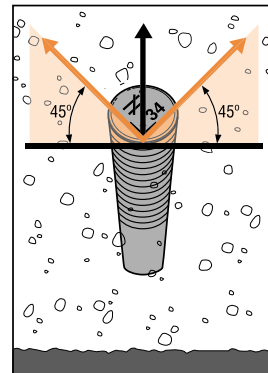
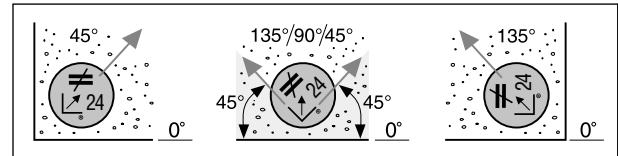

Install 45° from either edge
Instalar 45° de cada cara

STHD – w/StrapMate®

SIMPSON
Strong-Tie

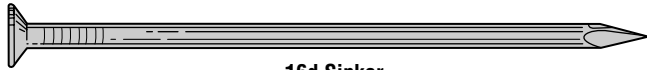

16d Sinker
(0.148" x 3¼")

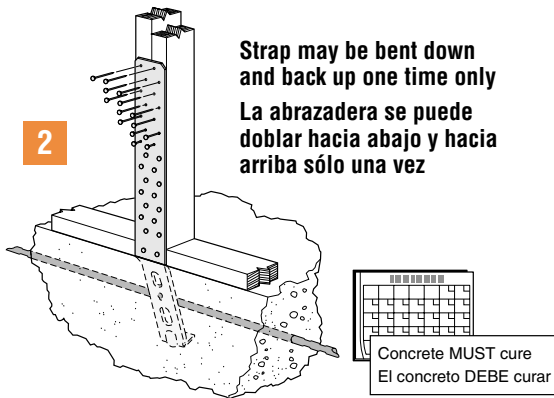
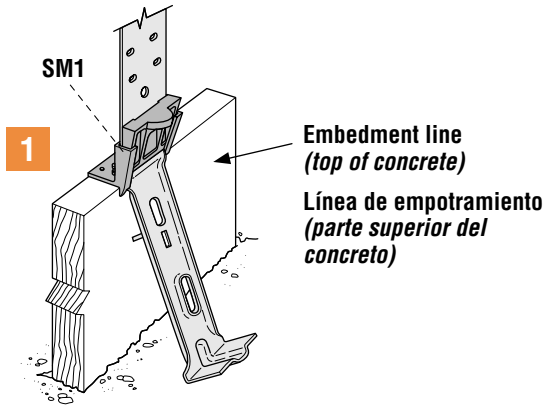

STC

SIMPSON
Strong-Tie

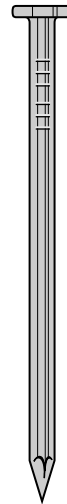

8d
(0.131" x 2½")

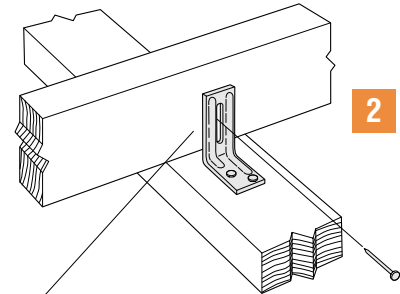
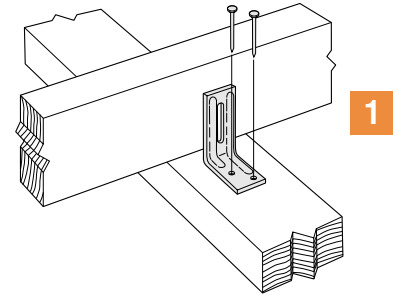

Install nail in center of slot
Instale el clavo en el centro de la ranura

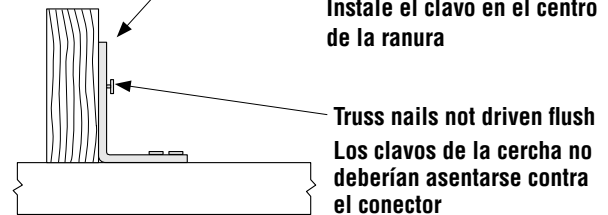

SUR/L

SIMPSON
Strong-Tie

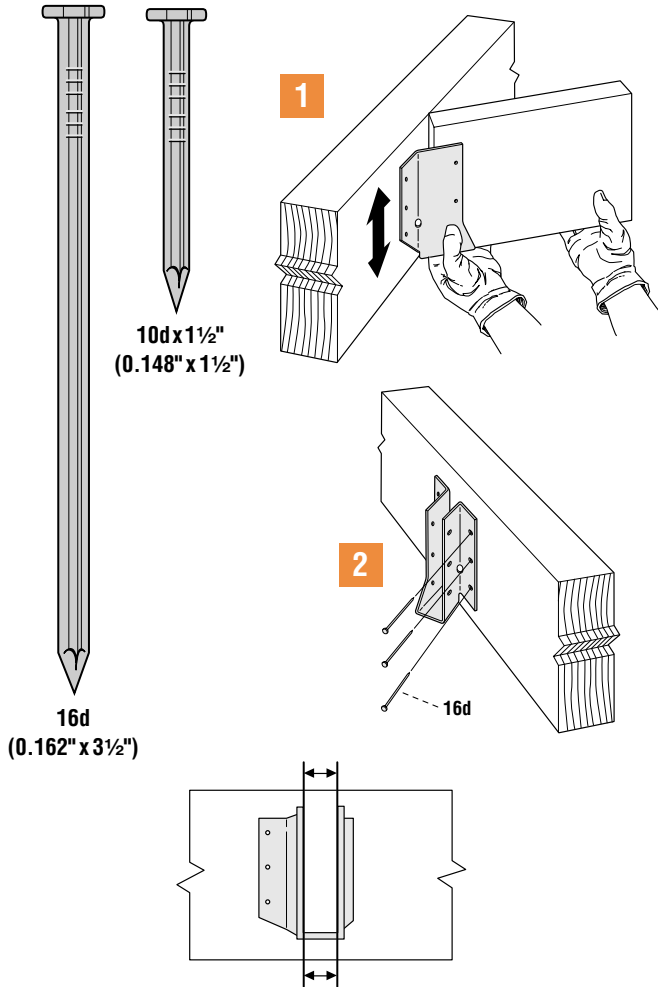

SUR/L

SIMPSON
Strong-Tie

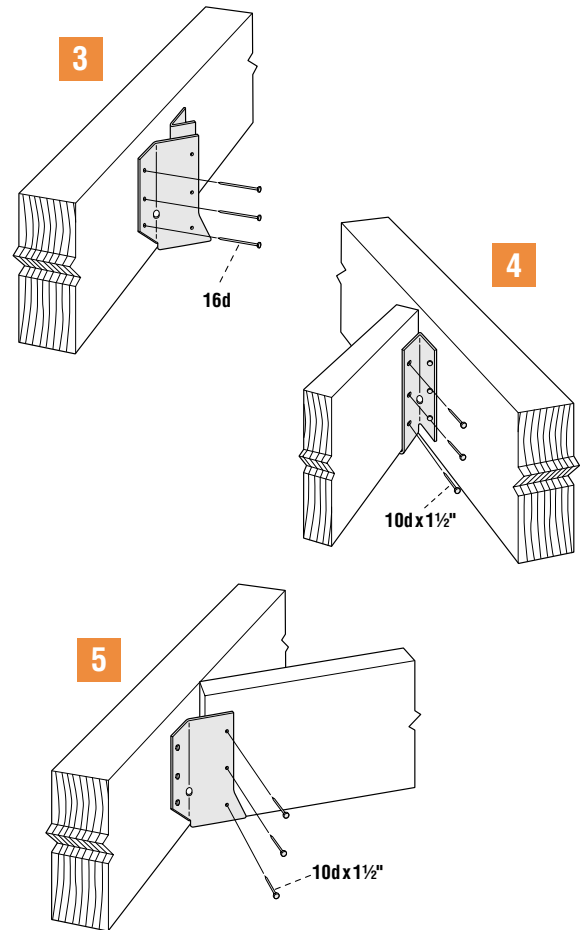

THA Installation on Solid Header Instalación Sobre Viga Cabezal Sólida

SIMPSON
Strong-Tie

Top-Mount Condition / Condición de Montaje Superior

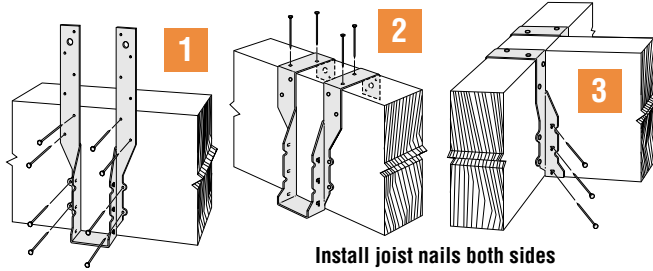

**Install joist nails both sides
Instale clavos para vigas a ambos lados**

Face Mount Condition / Condición de Montaje Sobre Cara

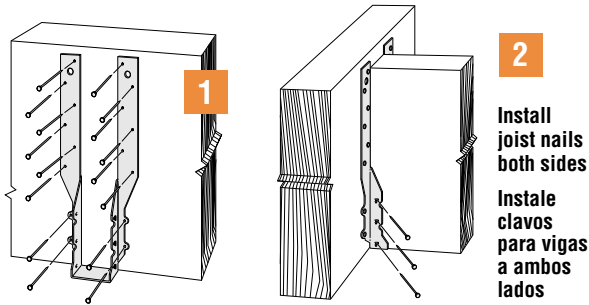

**Install joist nails both sides
Instale clavos para vigas a ambos lados**

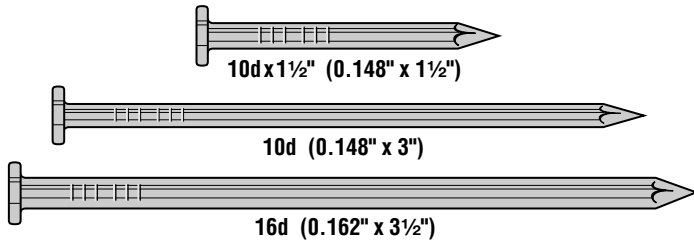

THA

SIMPSON
Strong-Tie

Installation on Solid Header Instalación Sobre Viga Cabezal Sólida

Modelo Modelo	Top & Face Encima & Cara	Carried Member Miembro Soportado
THA29	16-10d	4-10d
THA213	14-10d	4-10d
THA413		
THA218		
THA218-2	18-10d	4-10d
THA418		
THA422		
THA222-2		
THA422-2	22-16d	6-16d
THA426		
THA426	30-16d	6-16d

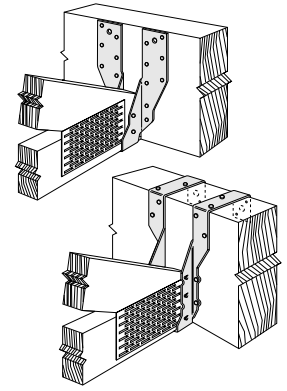

**Double 2x4 Top Chord Min.
Viga Superior Doble de 2 x 4 Como Mínimo**

Installation on Truss Instalación Sobre Cercha

Nail Location Ubicación de Los Clavos	Qty / Nail Cant./Clavo
Top / Encima	4-16d
Face / Cara	4-16d
Carried Member Miembro soportado	Fill all holes with 16d Llene todos los orificios con clavos 16d.

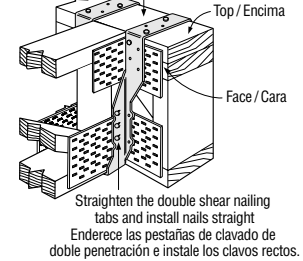

Installation on Nailer Instalación en Listón Clavador

Nail Location Ubicación de Los Clavos	4x Nailer / Listón Clavador 4x
Top / Encima	4-16d
Face / Cara	4-16d
Carried Member Miembro soportado	Fill all holes with 16d Llene todos los orificios con clavos 16d.

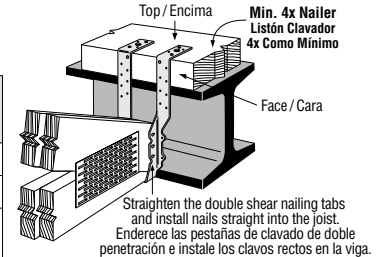

THJA

SIMPSON
Strong-Tie

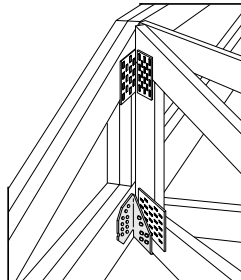
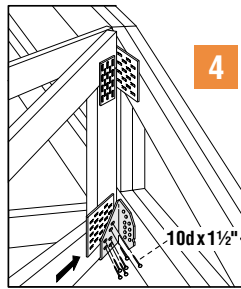
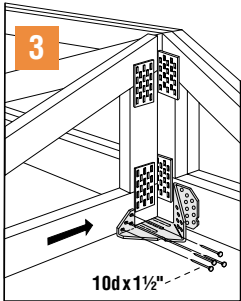
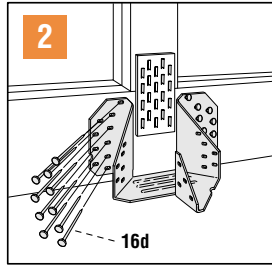
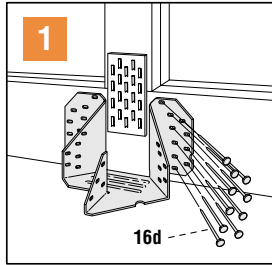
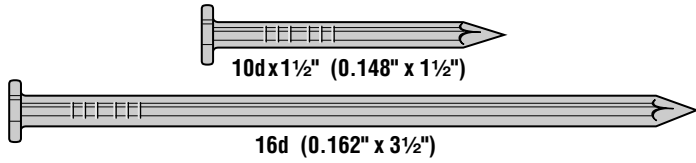

Left hand hip
installation similar
Similar a la instalación
'izquierda' de cumbre

THJU

SIMPSON
Strong-Tie

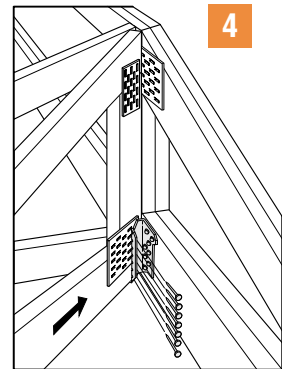
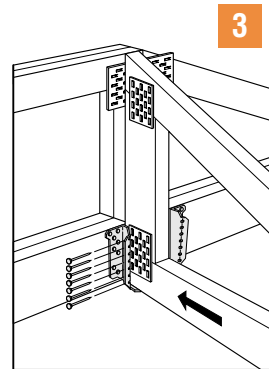
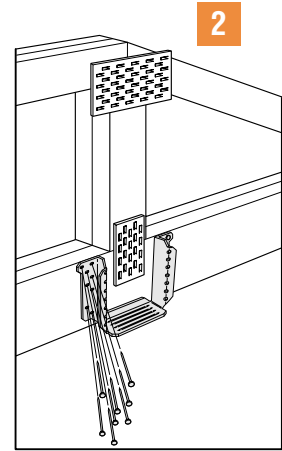
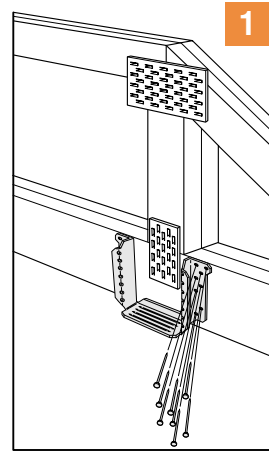
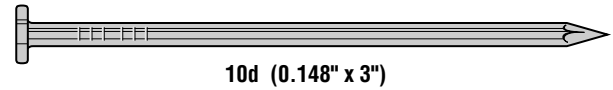

TSB

SIMPSON
Strong-Tie

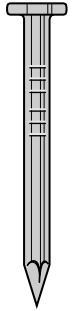

10d x 1 1/2"
(0.148" x 1 1/2")

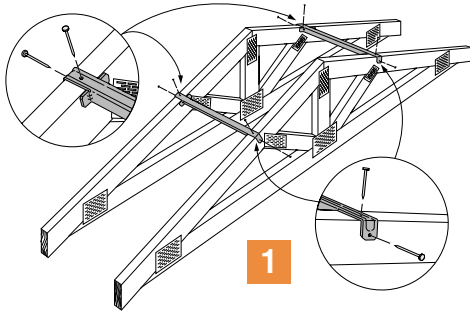

1

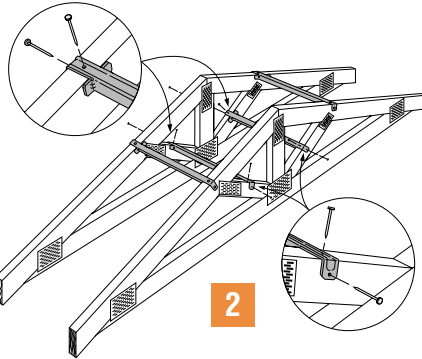

2

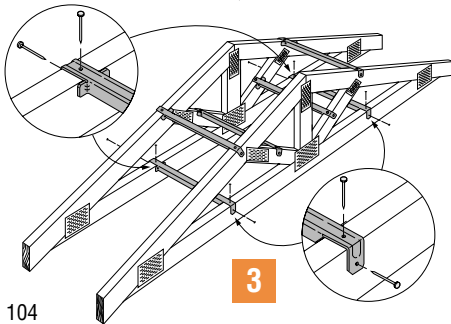

3

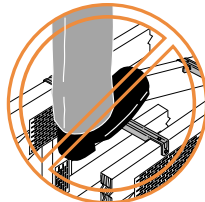

**NO STEP
NO PISAR**

TSB

SIMPSON
Strong-Tie

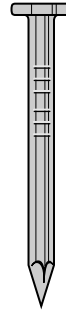

10d x 1 1/2"
(0.148" x 1 1/2")

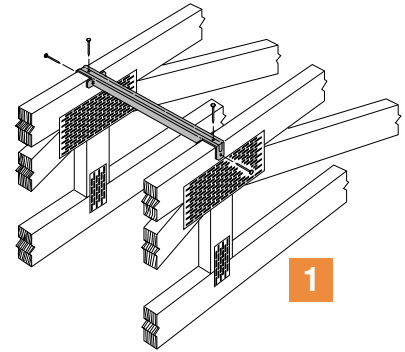

1

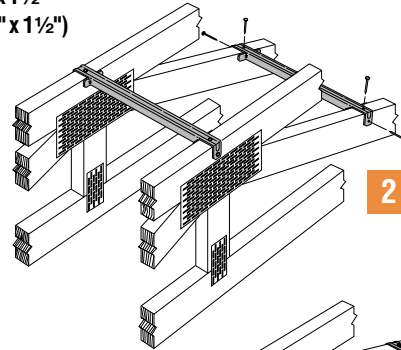

2

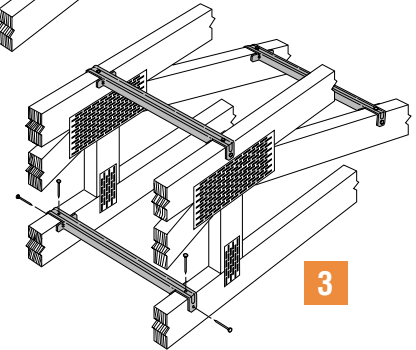

3

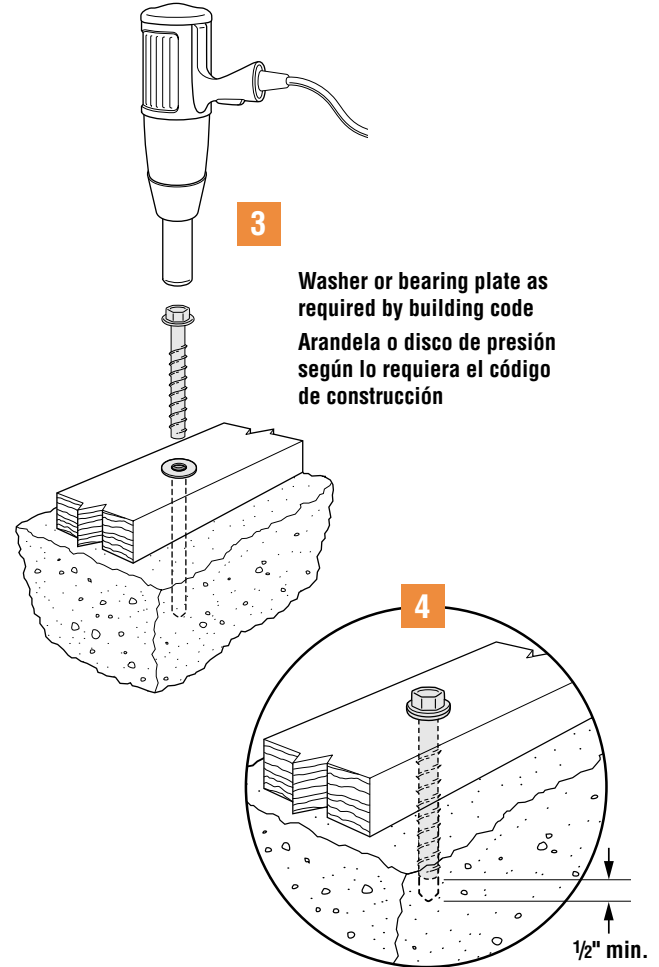
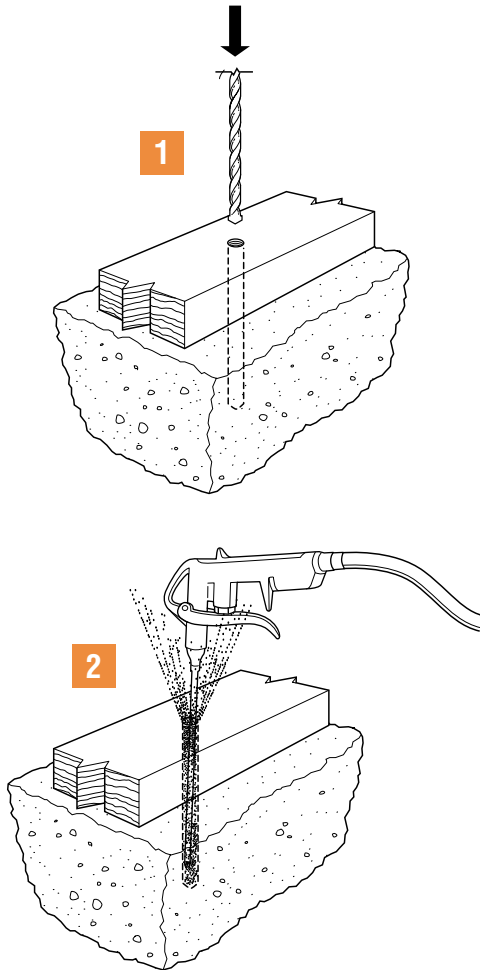

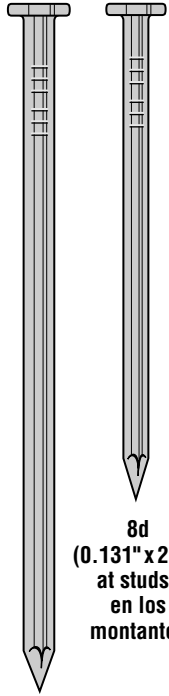

8d
(0.131" x 2 1/2")
at studs /
en los
montantes

16d
(0.162" x 3 1/2")
at plates /
en las soleras

Cut 5/8" kerf
Corte un corte
de 5/8"

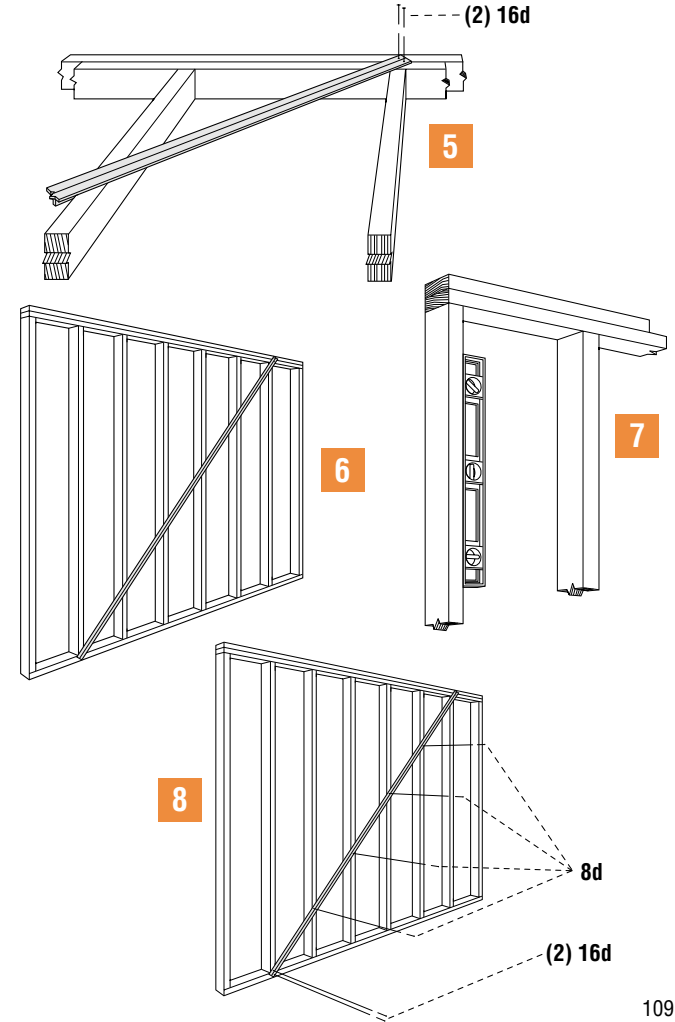
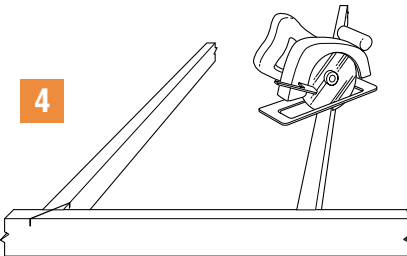
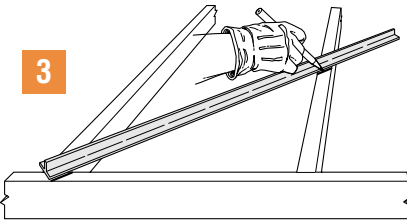
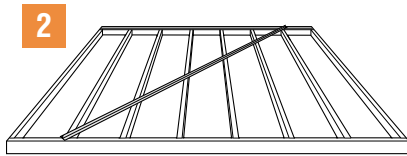
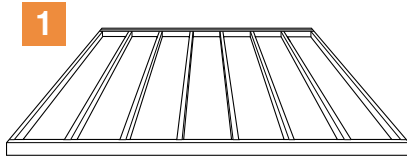



SDS 1/4" x 3"

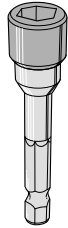

Use 3/8" driver
Use un
destornillador
de 3/8"

If using an adhesive anchor,
see page 24 for instructions.

Si utiliza un anclaje adhesivo,
consulte las instrucciones de
la página 24.

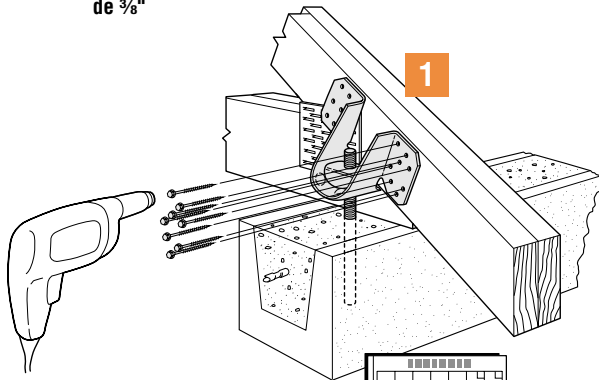

1

Concrete MUST cure
El concreto DEBE curar

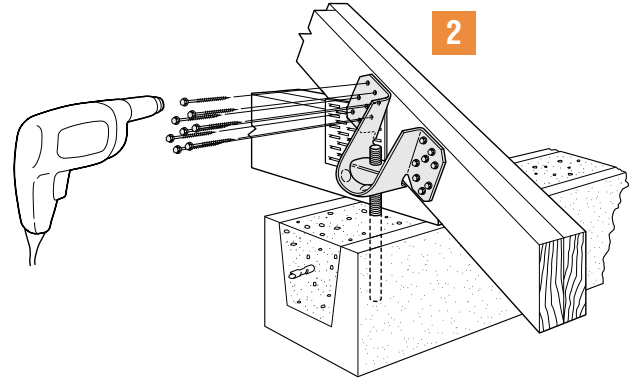

2

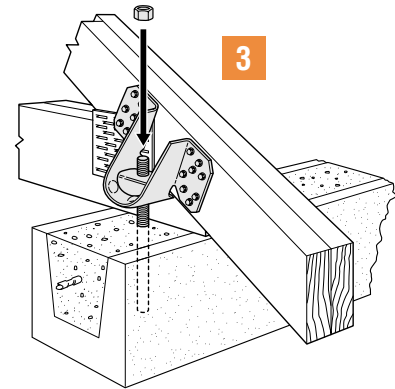

3

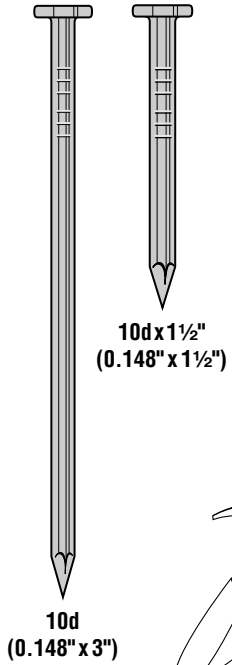

10d x 1½"
(0.148" x 1½")

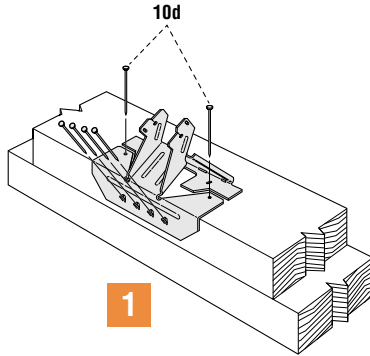

1

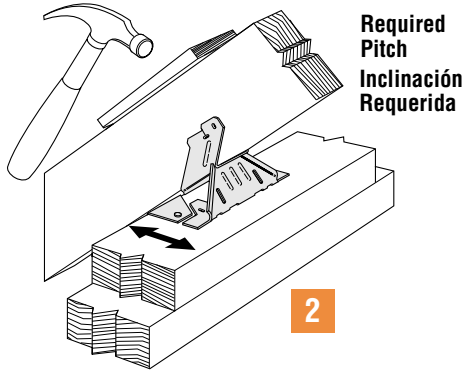

Required Pitch
Inclinación
Requerida

2

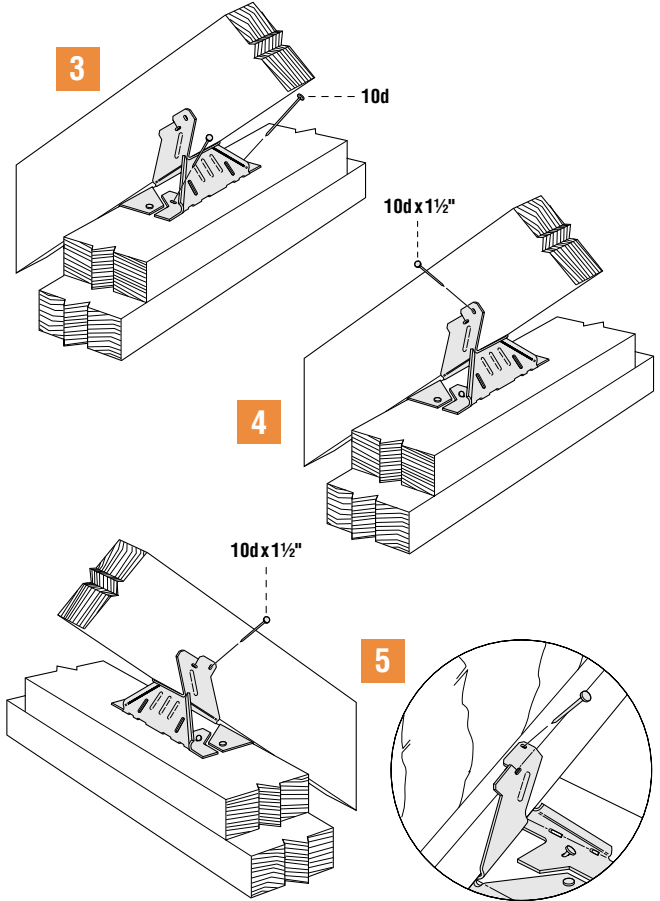

3

10d x 1½"

4

10d x 1½"

5

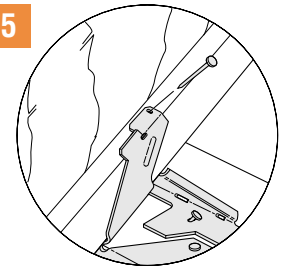

Solid Wood
Madera Sólida

I-Joist
Vigueta



